

# **INSTALLATION, MAINTENANCE AND OPERATION'S MANUAL**

*Trusted. Tested. True.®*

**CHIEF SPOOL ENCLOSED BELT CONVEYOR (CSEB)  
P/N 94-0-800009**

## Manual Revision

---

94-0-100008

v1.032024

Release

**Westgo Chief Philippines Corporation**  
Building 19, Philexcel Business Park, Clark Freeport Zone,  
Angeles City, Pampanga, Philippines 2009

For more informaton about Westgo Chief Philippines Corporation and or additional products or services please visit our website.

<https://asia.chiefind.ph/>

## TABLE OF CONTENTS

<b>Manual Revisions</b> .....	2
<b>Table of Contents</b> .....	3
<b>STANDARD LIMITED WARRANTY</b> .....	4
<b>Before You Begin</b> .....	9
<b>Accessory Equipment</b> .....	10
<b>General Contractor Responsibilities</b> .....	10
Field Modification and Installation .....	10
Checking Shipment .....	10
Suggested Equipment .....	11
Hardware Torque .....	11
<b>Belt Conveyor Safety</b> .....	12
General Safety .....	13
Assembly Safety .....	14
Operating Safety .....	14
Maintenance Safety .....	15
Safety Sign .....	15
Workplace Hazard Area .....	16
Safety Sign .....	17
<b>Installation</b> .....	18
Coveror Set-Up .....	18
Conveyor Belt Installation .....	18
<b>Operation</b> .....	22
Operating Safety .....	22
To the new operator or owner .....	22
Machine Components .....	23
Pre-Operation Checklist .....	25
Machine Breakin .....	25
<b>Controls</b> .....	26
Safety Device .....	26
Operating .....	27
Conveyor Loading and Discharge .....	28
Belt Cleaning Devices .....	30
Operation Equipment .....	31
<b>Service and Maintenance</b> .....	34
<b>Troubleshooting</b> .....	57
<b>Specification</b> .....	60

# STANDARD LIMITED WARRANTY

## Material Handling Products

**1. Definitions.** The following terms, when they appear in the body of this standard limited warranty for material handling products in initial capital letters shall have the meaning set forth below:

- A. Accepted purchase order shall mean the purchase order identified below.
- B. Westgo Chief shall mean Westgo Chief philippines corporation.
- C. Original owner shall mean the original owner identified below.
- D. Product shall mean the Westgo Chief equipment as described in the accepted purchase order.
- E. Reseller shall mean the authorized westgo chief philippines corporation equipment dealer identified below.

**2. Limited product warranty.** Upon and subject to the terms and conditions set forth below, Westgo Chief hereby warrants to the reseller, and, if different, the original owner as follows: All new products delivered to the reseller or the original owner by Westgo Chief pursuant to the accepted purchase order will, when delivered, conform to the specifications set forth in the accepted purchase order;

- F. All new products delivered pursuant to the accepted purchase order will, in normal use and service, be free from defect in materials or workmanship; and
- G. Upon delivery, Westgo Chief will convey good and marketable title to the products, free and clear of any liens or encumbrances except for, where applicable, a purchase money security interest in favor of Westgo Chief.

**3. Duration of warranty and notice requirements.** Subject to the exceptions, exclusions and limitations set forth below, the warranties set forth in section 2 above shall apply to all covered non-conforming conditions that are discovered within the first twenty-four (24) months following delivery of the product to the carrier designated by the reseller and/or the original owner at Westgo Chief's manufacturing facility in Philippines, Clark Freeport Zone, Pampanga (the "warranty period") and are reported to the Westgo Chief as provided in section 4 below within thirty (30) days following discovery (a "notice period").

**4. Notice procedure.** In order to make a valid warranty claim, the reseller and/or the original owner must provide Westgo Chief with a written notice of any nonconforming condition discovered during the warranty period within the applicable notice period specified in section 3 above. Said notice must be in writing; be addressed to Westgo Chief Philippines Corporation, Building 19, Clark Freeport Zone 2009, Philippines and contain the following information: (a) the customer's name and address; (b) the reseller's name and address; (c) the make and model of the product in question; (d) the current location of the product; (e) a brief description of the problem with respect to which warranty coverage is claimed; and (f) the date on which the product was purchased.

**5. Exceptions and exclusions.** Anything herein to the contrary notwithstanding, the warranties set forth in section 2 above do **not** cover any of the following, each of which are hereby expressly excluded:

- A. Defects that are not discovered during the applicable warranty period;
- B. Defects that are not reported to the Westgo Chief Philippines Corporation customer service department in conformity with the notice procedure set forth in section 4 above within the applicable notice period specified in section 3;
- C. Any used or pre-owned products;
- D. Any Westgo Chief manufactured parts that are not furnished as a part of the accepted purchase order;
- E. Any fixtures, equipment, materials, supplies, accessories, parts or components that have been furnished by Westgo Chief but are manufactured by a third party;
- F. Any products which have been removed from the location at which they were originally installed;
- G. Any defect, loss, damage, cost or expense incurred by the Reseller or the Original Owner to the extent the same arise out of, relate to or result, in whole or in part, from any one or more of the following:
  - (i) Usual and customary deterioration, wear or tear resulting from normal use, service and exposure;

- (ii) Theft, vandalism, accident, war, insurrection, fire or other casualty;
- (iii) Any damage, shortages or missing parts which result during shipping or are otherwise caused by the Reseller, the Original Owner and/or any third party;
- (iv) Exposure to marine environments, including frequent or sustained salt or fresh water spray;
- (v) Exposure to corrosive, chemical, ash, smoke, fumes, or the like generated or released either within or outside of the structure on which the Product is installed, regardless of whether or not such facilities are owned or operated by the Reseller, the Original Owner or an unrelated third party;
- (vi) Exposure to or contact with animals, animal waste and/or decomposition;
- (vii) The effect or influence the Product may have on surrounding structures, including, without limitation, any loss, damage or expense caused by drifting snow;
- (viii) Any Product or portion thereof that has been altered, modified or repaired by the Reseller, the Original Owner or any third party without Westgo Chief's prior written consent;
- (ix) Any Product or portion thereof that has been attached to any adjacent structure without Westgo Chief's prior written approval;
- (x) Any Product to which any fixtures, equipment, accessories, materials, parts or components which were not provided as a part of the original Accepted Purchase Order have been attached without Westgo Chief's prior written approval;
- (xi) The failure on the part of the Reseller, the Original Owner or its or their third party contractors to satisfy the requirements of all applicable statutes, laws, ordinances rules, regulations and codes, (including zoning laws and/or building codes);
- (xii) The use of the Product for any purpose other than the purpose for which it was designed; and/or
- (xiii) The failure of the Reseller, the Original Owner and/or any third party to:
  - (a) properly handle, transport and/or store the Product or any component part thereof;
  - (b) properly select and prepare a site that is adequate for the installation and/or operation of the Product or any component part thereof;
  - (c) properly design and construct a foundation that is adequate for the installation and/or operation of the Product or any component part thereof;
  - (d) properly set up, erect, construct or install the Product and/or any component part thereof; and/or
  - (e) properly operate, use, service and/or maintain the Product and each component part thereof.

**6. Resolution of Warranty Claims.** In the event any nonconforming condition is discovered within the Warranty Period and Westgo Chief is notified of a warranty claim as required by Section 4 prior to the end of the applicable Notice Period set forth in Section 3 above, Westgo Chief shall, with the full cooperation of the Reseller and the Original Owner, immediately undertake an investigation of such claim. To the extent Westgo Chief shall determine, in its reasonable discretion, that the warranty claim is covered by the foregoing Limited Product Warranty, the following shall apply:

A. Warranty Claims With Respect to Covered Non-Conforming Conditions Discovered Within the First Three Hundred Sixty Five (365) Days and Reported to Westgo Chief Within Thirty (30) Days of Discovery. In the case of a warranty claim which relates to a covered non-conforming condition that is discovered during the first three hundred sixty five (365) days of the Warranty Period and is reported to Westgo Chief as required by Section 4 within thirty (30) days of discovery as required by Section 3, Westgo Chief will, as Westgo Chief's sole and exclusive obligation to the Reseller and the Original Owner, and as their sole and exclusive remedy, work in cooperation with the Reseller and the Original Owner to correct such non-conforming condition, and in connection therewith, Westgo Chief will ship any required replacement parts to the "ship to address" set forth in the Accepted Purchase Order FOB. Westgo Chief's facilities in Philippines, Clark Freeport Zone, Pampanga and will either provide the labor or reimburse the Reseller or the Original Owner, as may be appropriate in the circumstances, for any out of pocket expense the Original Owner may reasonably and necessarily incur for the labor that is required to correct such non-conforming condition, provided that if work is to be performed by the Reseller or a third party contractor, Westgo Chief may require at least two competitive bids to perform the labor required to repair or correct the defect and reserves the right to reject all bids and obtain additional bids. Upon acceptance of a bid by Westgo Chief, Westgo Chief will authorize the necessary repairs.

- B. **All Other Warranty Claims.** Except as is otherwise provided in subsection 6A above, in the case of all other warranty claims which relate to covered non-conforming conditions that are discovered during the Warranty Period and are reported to Westgo Chief as required by Section 4 within thirty (30) days following discovery, Westgo Chief will, as Westgo Chief's sole and exclusive obligation to the Reseller and the Original Owner, and as the Reseller's and the Original Owner's sole and exclusive remedy, ship any required replacement parts to the Original Owner at the "ship to address" specified in the Accepted Purchase Order FOB Westgo Chief's facilities in Philippines, Clark Freeport Zone, Pampanga; and in such event, Westgo Chief shall have no responsibility or liability to either the Reseller or the Original Owner for the cost of any labor required to repair or correct the defect.
7. **Warranty Not Transferable.** This Warranty applies only to the Reseller and the Original Owner and is not transferable. As such, this Warranty does not cover any Product that is sold or otherwise transferred to any third party following its delivery to the Original Owner.
8. **Limitation on Warranties, Liabilities and Damages.** The Reseller and the Original Owner expressly agree that the allocation of the risk, liability, loss, damage, cost and expense arising from any Product that does not conform to the limited warranty given in Section 2 above are fair and reasonable and acknowledge that such allocation was expressly negotiated by the parties and was reflected in the Purchase Price of the Product. Accordingly the Reseller and the Original Owner expressly agree as follows:
- A. **Disclaimer of Implied Warranties.** EXCEPT AS IS OTHERWISE EXPRESSLY SET FORTH HEREIN, WESTGO CHIEF MAKES NO OTHER REPRESENTATIONS OR WARRANTIES OF ANY KIND WHATSOEVER, WHETHER EXPRESS OR IMPLIED, BY OPERATION OF LAW, COURSE OF DEALING OR OTHERWISE WITH RESPECT TO THE PRODUCT, ANY COMPONENT PART THEREOF OR ANY OTHER GOODS OR SERVICES THAT CHIEF MANUFACTURES, FABRICATES, PRODUCES, SELLS OR PROVIDES TO THE DEALER OR THE ORIGINAL OWNER PURSUANT TO THE TERMS OF ANY ACCEPTED PURCHASE ORDER, INCLUDING WITHOUT LIMITATION ANY REPRESENTATION OR WARRANTY WITH RESPECT TO DESIGN, CONDITION, MERCHANTABILITY OR FITNESS OF THE PRODUCT OR ANY OTHER GOODS OR SERVICES FOR ANY PARTICULAR PURPOSE OR USE.
- B. **Limitation on Liability.** EXCEPT AS IS OTHERWISE EXPRESSLY SET FORTH IN SECTION 6 ABOVE, WESTGO CHIEF'S LIABILITY TO THE DEALER AND/OR THE ORIGINAL OWNER WITH RESPECT TO ANY DEFECTS IN ANY PRODUCTS OR FOR ANY OTHER GOODS OR SERVICES WHICH DO NOT CONFORM TO THE WARRANTIES SET FORTH ABOVE SHALL NOT, IN ANY EVENT, EXCEED THE ACTUAL COST OF SUCH NON-CONFORMING PRODUCT, GOODS OR SERVICES AS DETERMINED PURSUANT TO THE ACCEPTED PURCHASE ORDER; AND
- C. **Limitation on the Nature of Damages.** EXCEPT AS EXPRESSLY PROVIDED IN SECTION 6 ABOVE, WESTGO CHIEF SHALL NOT, UNDER ANY CIRCUMSTANCES, BE LIABLE TO THE DEALER, THE ORIGINAL OWNER OR ANY THIRD PARTY FOR ATTORNEY FEES COURT COSTS OR ANY OTHER SPECIAL, INDIRECT, INCIDENTAL, CONSEQUENTIAL, LIQUIDATED OR PUNITIVE DAMAGES OF ANY NAME, NATURE OR DESCRIPTION AS A RESULT OF THE FAILURE OF ANY PRODUCT OR ANY OTHER GOODS OR SERVICES PURCHASED BY THE DEALER OR THE ORIGINAL OWNER FROM WESTGO CHIEF PURSUANT TO THE ACCEPTED PURCHASE ORDER TO CONFORM TO THE LIMITED WARRANTIES SET FORTH IN SECTION 2 ABOVE.
9. **Applicable Law.** This Limited Product Warranty has been issued, accepted and entered into by the Reseller, the Original Owner and Westgo Chief in the Philippines and shall be governed by, and construed in accordance with, the internal laws of the Philippines. Any legal action or proceeding with respect to any goods or services furnished to the Original Owner by Westgo Chief in connection herewith, or any document related hereto shall be brought only in the judicial courts of Philippines and, by execution and delivery of this Limited Product Warranty, the undersigned Original Owner hereby accept for themselves and with respect to their property, generally and unconditionally, the jurisdiction of the aforesaid courts. Further, the undersigned Original Owner hereby irrevocably waives any objection, including, without limitation, any forum non conveniens, which it may now or hereafter have to the bringing of such action or proceeding in such respective jurisdictions.

**ACKNOWLEDGMENT OF RECEIPT**

By its signature hereto, the undersigned Reseller represents and warrants to Chief that the Reseller has provided a true, correct and complete copy of this Standard Limited Warranty to the Original Owner at the time the product was purchased.

**Reseller Name and Address:** \_\_\_\_\_  
\_\_\_\_\_  
\_\_\_\_\_

**Original Owner Name and Address:** \_\_\_\_\_  
\_\_\_\_\_  
\_\_\_\_\_

**Accepted Purchase Order No.** \_\_\_\_\_

**Original Jobsite Address:** \_\_\_\_\_  
\_\_\_\_\_  
\_\_\_\_\_

**RESELLER:**

By: \_\_\_\_\_  
Date

\_\_\_\_\_  
Print name and title

## **Warning**

### **Water Sensitive Materials - Read this notice carefully**

Items must be inspected and carrier advised immediately if damage is noted. White rust is a corrosion attack of the zinc coating resulting from the presence of water. Anywhere rust is found will result in a reduction of the life of the galvanized steel.

If water has entered a bundle or if condensation has formed between items, the bundle must be opened, the items separated and all surfaces dried.

#### **If items are to be installed within 10 days:**

Store bundled items off the ground high enough to allow air circulation beneath bundle and to prevent water from entering. Store 1 end at least 8" (20.32cm) higher than the opposite end. Support long bundles in the center. Prevent rain from entering the bundle by covering with a tarpaulin, making provision for air circulation between the draped edges and the ground.

#### **Do not wrap in plastic.**

#### **If items are not to be installed within 10 days:**

Provide inside dry storage. Storage beyond 6 months is not recommended. If white rust is apparent upon receipt of shipment, notify Westgo Chief immediately. Damage to items, resulting from improper storage, is the responsibility of the receiver.



## BEFORE YOU BEGIN

Before starting the installation of the belt conveyor, take time to thoroughly study the construction methods in this manual, this will save you time and money.

Westgo Chief makes no warranty concerning components, accessories or equipment not manufactured by Westgo Chief.

When using a cutting torch or welding galvanized material, the possibility of developing toxic fumes will exist. Provide adequate ventilation and respiratory protection when using this type of equipment during installation.

## Introduction

Thank you for purchasing a Westgo Chief belt conveyor. Proper installation and operation will ensure the best overall experience with your equipment.

This proprietary information is loaned with the expressed agreement that the drawings and information herein contained are the property of Westgo Chief Philippines Corporation and will not be reproduced, copied, or otherwise disposed of, directly or indirectly, and will not be used in whole or in part to assist in making or to furnish any information for the making of drawings, prints or other reproduction hereof, or for the making of additional products or equipment except upon written permission of Westgo Chief Philippines Corporation first obtained and specific as to each case. The acceptance of this material will be construed as an acceptance of the foregoing agreement.

The technical data contained herein is the most recent available at the time of publication and is subject to modification without notice. Westgo Chief Philippines Corporation reserves the right to modify the construction and method of operation of their products at any time without any obligation on their part to modify any equipment previously sold and delivered.

**Important Note:** If you are unable to remedy any service problem after thoroughly studying this manual, contact the dealer from whom you purchased the unit. Your dealer is your first line of service. The following information is required for service:

- Belt conveyor model and serial number: \_\_\_\_\_ .
- Pulley size and number of teeth: \_\_\_\_\_ .
- Overall length: \_\_\_\_\_ .
- Motor RPM and HP: \_\_\_\_\_ .
- Type of grain and capacity: \_\_\_\_\_ .
- Dealer purchased from: \_\_\_\_\_ .
- Dealer address and phone number: \_\_\_\_\_ .
- Date purchased: \_\_\_\_\_ .
- Service contractor: \_\_\_\_\_ .
- Name: \_\_\_\_\_ .
- Address: \_\_\_\_\_ .
- Phone: \_\_\_\_\_ .

## Accessory Equipment

All accessory equipment should be installed and maintained in accordance with each individual supplier's installation and operation instructions. However, if any modifications to the Westgo Chief standard design are required, contact Westgo Chief for special recommendations.

Important Note: Do not modify the belt conveyor design without Westgo Chief approval. It is the responsibility of the general contractor to verify that all equipment is properly installed, and that the equipment is compatible with the intended use. A qualified electrician should be contracted to complete all electrical wiring and servicing.

## General Contractor Responsibilities

It is the responsibility of the general contractor to verify that the complete system (belt conveyor, and other accessory equipment) is constructed with quality workmanship and that all equipment is installed per the respective manufacturer's instructions.

In addition, the general contractor is responsible for the fitness of use of any system which he constructs. All accessory equipment incorporated into the system should be approved for the intended use by each respective equipment manufacturer.

## Field Modifications and Installation Defects

Westgo Chief assumes no responsibility for field modifications or installation defects which result in damage or operational problems. If any field modifications are necessary which are not specifically covered by the contents of this installation manual or project specific installation drawings supplied by Westgo Chief, contact Westgo Chief for approval. Any unauthorized modification or installation defect which affects the operation of the belt conveyor will void the warranty.

## Checking Shipment

For your convenience individual items will be labeled with an appropriate part number and packages labeled. Hardware, including bolts, nuts, screws and other small clips or brackets may be divided into smaller packages for ease of use and identification.

Check your shipment at the time of delivery against the packing list provided with the shipment. If any items are missing or any damaged material is evident, note such shortage or damage on the freight bill before you sign the shipment paperwork.

Claims of shortages will not be honored after 30 days from receipt of shipment. Parts that are missing or damaged are the responsibility of the delivering carrier, not the manufacturer or dealer. It is advisable to reorder damaged or missing parts immediately so that there will be no delay in the installation. After receiving the invoice for the reordered material, file a claim with the delivering carrier immediately.

## Suggested Equipment

Chief recommends the following equipment and tools needed for installation. Individual installations may vary.

- Impact wrenches and sockets
- End wrenches
- Crescent wrenches
- Vise grip pliers
- Alignment punches
- Rubber mallets
- Level
- Drill and drill bits
- Screw Guns
- Metal Saw
- Extension cords

## Hardware Torque

The following table contains recommended minimum and maximum torque values for installation.

When installing hardware the minimum and maximum torque values shown below must be followed. All hardware must seat tight against the corresponding bin component.

Bolt Diameter	Torque
5/16" (8mm)	16 ft.-lbs. (22N-m)
3/8" (10mm)	29 ft.-lbs (39N-m)
7/16" (11mm)	46 ft.-lbs. (62N-m)
1/2" (13mm)	70 ft.-lbs (95N-m)
5/8" (16mm)	140 ft.-lbs (190N-m)
3/4" (19mm)	250 ft.-lbs (340N-m)
7/8" (22mm)	400 ft.-lbs (542N-m)
1" (25mm)	600 ft.-lbs. (813N-m)
1 1/2" (29mm)	750 ft.-lbs (1017N-m)
1 1/4" (32mm)	1100 ft.-lbs (1491N-m)

# Belt Conveyor Safety

This Safety Alert Symbol means **ATTENTION! BECOME ALERT! YOUR SAFETY IS INVOLVED!**



The Safety Alert symbol identifies important safety messages on the Chief Spool Enclosed Belt Conveyor and in the manual. When you see this symbol, be alert to the possibility of personal injury or death. Follow the instructions in the safety message.

## Why is SAFETY important to you?

**Accidents Disable and Kill  
Accidents Cost  
Accidents Can Be Avoided**

### 3 Big Reasons

#### SIGNAL WORDS:

Note the use of the signal words DANGER, WARNING, CAUTION, IMPORTANT and NOTE with the safety messages. The appropriate signal word for each message has been selected using the following guidelines.

**DANGER** - Indicates an imminently hazardous situation that, if not avoided, will result in death or serious injury. This signal word is to be limited to the most extreme situations, typically for machine components that, for functional purposes, cannot be guarded.

**WARNING** - Indicates a potentially hazardous situation that, if not avoided, could result in death or serious injury, and includes hazards that are exposed when guards are removed. It may also be used to alert against unsafe practices.

**CAUTION** - Indicates a potentially hazardous situation that, if not avoided, may result in minor or moderate injury. It may also be used to alert against unsafe practices. Instructions that must be followed to ensure proper installation/operation of equipment.

**NOTE** - General statements to assist the reader

## Safety

YOU are responsible for the SAFE operation and maintenance of your Chief Spool Enclosed Belt Conveyor. YOU must ensure that you and anyone else who is going to operate, maintain or work around the Chief Spool Enclosed Belt Conveyor be familiar with the operating and maintenance procedures and relate SAFETY information contained in this manual. This manual will alert you to all good safety practices that should be adhered to while operating the Chief Spool Enclosed Belt Conveyor.

Remember, YOU are the key to safety. Good safety practices not only protect you but also the people around you. Make these practices a working part of your safety program. Be certain that EVERYONE operating this equipment is familiar with the recommended operating and maintenance procedures and follows all the safety precautions. Most accidents can be prevented. Do not risk injury or death by ignoring good safety practices.

- Chief Spool Enclosed Belt Conveyor owners must give operating instructions to operators or employees before allowing them to operate the machine, and at least annually thereafter per OSHA (Occupational Safety and

Health Administration) regulation 1928.57.

- The most important safety device on this equipment is a SAFE operator. It is the operator's responsibility to read and understand ALL Safety and Operating instructions in the manual and to follow them. All accidents can be avoided.

- A person who has not read and understood all operating and safety instructions is not qualified to operate the machine. An untrained operator exposes himself and bystanders to possible serious injury or death.

- Do not modify the equipment in anyway. Unauthorized modification may impair the function and/or safety and could affect the life of the equipment.

- Think SAFETY! Work SAFELY!

## General Safety

Read and understand the Operator's Manual and all safety signs before operating, maintaining, adjusting or unplugging the Chief Spool Enclosed Belt conveyor.

2. Only trained persons shall operate the conveyor. An untrained operator is not qualified to operate the machine.

3. Have a first-aid kit available for use should the need arise and know how to use it.

4. Provide a fire extinguisher for use in case of an accident. Store in a highly visible place.

5. Do not allow children, spectators or bystanders within the Workplace Hazard Area of the machine. ("See Section 2.6 Workplace Hazard Area")

6. Wear appropriate protective gear. This list Includes but is not limited to:

- A hard hat
- Protective shoes with slip resistant soles
- Protective goggles
- Heavy gloves
- Hearing protection
- Respirator or filter mask

7. Place all controls in neutral or off, stop the motor, and wait for all moving parts to stop. Then disable power source before servicing, adjusting, repairing, or unplugging.

8. Review safety related items annually with all personnel who will be operating or maintaining the Chief Spool Enclosed Belt Conveyor.

## Assembly Safety

1. Assemble in an area with sufficient space to handle the largest component and allows access to all sides of the machine
2. Use only lifts, cranes and tools with sufficient capacity for the load.
3. When necessary, have someone assist you.
4. Do not allow spectators in the working area.
5. Be sure to read the maintenance safety section.

## Operating Safety

1. Read and understand the Operator's Manual and all safety signs before using.
2. Only trained personnel should be allowed to operate the conveyor system. They should have complete knowledge of conveyor operation, electrical controls, safety and warning devices, and the capacity and performance limitations of the system.
3. Disconnect and disable electrical supply completely and wait for all moving parts to stop before servicing, adjusting, repairing or unplugging.
4. Clear the area of bystanders, especially children, before starting.
5. Keep hands, feet, hair and loose clothing away from all moving and/or rotating parts.
6. Do not operate machine when any guards are removed.
7. No person should be allowed to ride on, or cross over a moving conveyor. Personnel must use walkways, stairs, ladders, and crossovers provided.
8. Be aware of the hazards of the type of material that is being conveyed. Some materials contain explosive dust. See table at back of manual.
9. Review safety related items annually with all personnel who will be operating or maintaining the conveyor.
10. At no time should the conveyors be used to handle material other than that originally specified. Capacity and belt speed design ratings should not be exceeded.
11. Conveyor covers can become slippery. Do not Step, Stand, Climb or Walk on conveyor covers. Serious Injury or death can occur from Stepping, Standing, Climbing or Walking on conveyor covers. Top covers are not designed to withstand a load.
12. Good housekeeping is a prerequisite for safe conditions. All areas around a conveyor, and particularly those surrounding drives, walkways, safety devices, and control stations, should be kept free of debris and obstacles.
13. Good lighting contributes to a safe working environment.

## Maintenance Safety

1. Review the Operator's Manual and all safety items before working with, maintaining or operating the conveyor.
2. Place all controls in neutral or off, stop motor, disable power source and wait for all moving parts to stop before servicing, adjusting, repairing or unplugging.
3. Follow good shop practices:
  - Keep service area clean and dry.
  - Be sure electrical outlets and tools are properly grounded.
  - Use adequate light for the job at hand.
4. Keep hands, feet, hair and clothing away from all moving and/or rotating parts.
5. Clear the area of bystanders, especially children, when carrying out any maintenance and repairs or making any adjustments.
6. Before resuming work, install and secure all guards when maintenance work is completed.
7. Do not Step, Stand, Climb or Walk on conveyor covers. Serious Injury Or Death can occur from Stepping, Standing, Climbing or Walking on conveyor covers. Conveyor covers can become slippery. Top covers are not designed to withstand a load.
8. Keep safety signs clean. Replace any sign that is damaged or not clearly visible.
9. Remove only one guard, cover, or hatch at a time, and replace it as soon as you are done inspecting or servicing the conveyor.
10. Do not poke anything into the conveyor to clear a jam.
11. Maintain strict housekeeping procedures: Clean up fugitive material, which can be dangerous when accumulated around the conveyor.

## Safety Signs

1. Keep safety signs clean and legible at all times.
2. Replace safety signs that are missing or have become illegible.
3. Replaced parts that displayed a safety sign should also display the current sign.
4. Safety signs that need to be replaced, are to be placed back in the original location. (See section 3.0 SAFETY SIGNS), for correct placement of safety decals.
5. Safety signs are available from your Distributor or the factory.

### How to Install Safety Signs:

- Be sure that the installation area is clean and dry.
- Be sure temperature is above 50° F (10° C).
- Decide on the exact position before you remove the backing paper.
- Remove the smallest portion of the split backing paper.
- Align the sign over the specified area and carefully press the small portion with the exposed sticky backing in place.
- Slowly peel back the remaining paper and carefully smooth the remaining portion of the sign in place.
- Small air pockets can be pierced with a pin and smoothed out using the piece of sign backing paper.

### Workplace Hazard Area

- 1. (Refer to diagram on next page). Only allow authorized personnel near the machine.
- 2. Stay out of shaded hazard area.
- 3. Always know where all additional personnel are located when operating the machine.

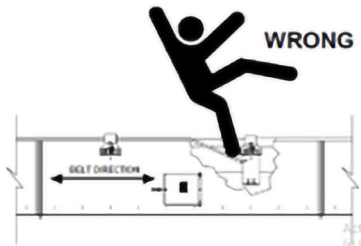
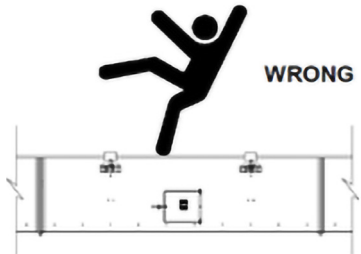

DO NOT STEP, STAND, CLIMB OR WALK ON CONVEYOR COVERS



**CAUTION**

MAKE CERTAIN EVERYONE IS CLEAR BEAFORE OPERATING THE MACHINE. KEEP CHILDREN, VISITORS AND UNTRAINED PEOPLE AWAY



STAY AWAY FROM HAZARD AREA



WALKING SURFACE IS IT SLIPPERY? ARE THERE THINGS TO TRIP YOU?

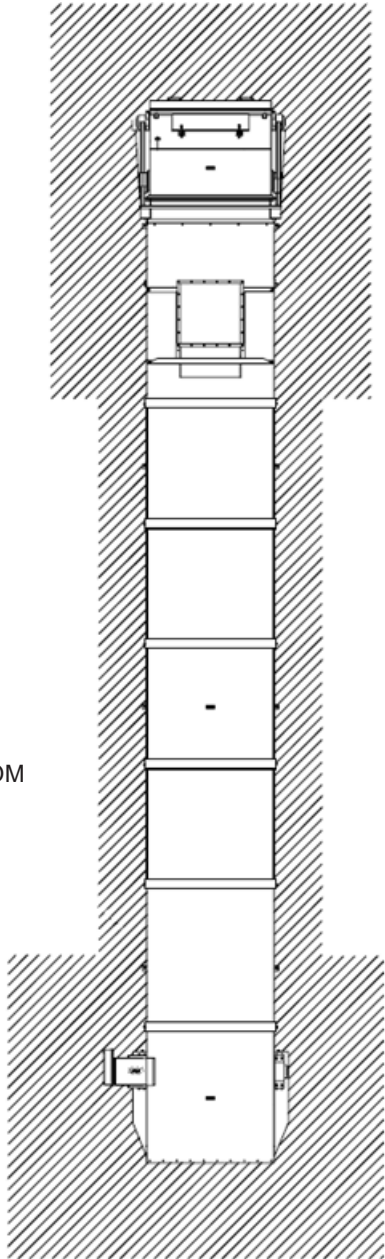

WORK AREA AUTHORIZED PERSONNEL ONLY



## Safety Sign

The following decals are installed at appropriate locations. Keep the decals clean at all times. If decals are no longer readable or missing, they must be replaced. Contact Chief Industries for replacement decals.



# Installation

## ASSEMBLY SAFETY

1. Assemble in an area with sufficient space to handle the largest component and allows access to all sides of the machine
2. Use only lifts, cranes and tools with sufficient capacity for the load.
3. When necessary, have someone assist you.
4. Do not allow spectators in the working area.
5. Be sure to read the maintenance safety section.

## Conveyor Set-up

Installation of your Chief Spool Enclosed Belt conveyor is vital to its performance and longevity. By following this procedure for installation, you should have many years of use from your conveyor.

1. Unpack and or un-crate your conveyor near or at the final installation site.
2. Place near desired location.
3. Level and square all framework and conveyor components.
  - A. The conveyor must be true relative to the centerline.
  - B. The conveyor must be level from side to side.
  - C. All rollers, and pulleys must be square with the frame. In addition, they must be perpendicular to the belt centerline and parallel to one another.
  - D. Sufficient clearance must be provided on both sides, under and below the head, tail, and mid sections.
  - E. Belt ends need to be examined to make sure they are squared.
  - F. To assure alignment of items A, B, and C, a survey instrument may be used to sight a straight line parallel to direction of belt travel. Having this completed, make sure the axes of pulleys, deflection wheels, and rollers are perpendicular to that line.
4. Bolt conveyor frames together using the required hardware and torque to the required specifications.
5. If required, anchor the supporting legs to concrete or concrete pads with anchor bolts or equivalent.

## Conveyor Belt Installation

Installation of the conveyor belt is an important set-up step in the installation of your conveyor. When installing the conveyor belt, follow this procedure.

The recommended, and certainly most common loading zones are at the tail. Any plans for the erection of surrounding structural members, installation of machinery, or assembly of conveyor components and covers should be scheduled to allow for the location of the belting in this manner. In the event this preferred method is not practical, the location of the belting for installation should allow for the adherence to these

guidelines as closely as possible, while remembering that the safest, fastest, and most economical location for the splicing of the belt will be at the section with the lowest belt tensions usually the loading zone.

#### 1. Timing of Installation:

Conveyor belting should be installed only when ready for use.

#### 2. Positioning of the belt:

Remove any banding and packaging necessary to allow free access to the belt.

To avoid inadvertent damage, protect the belt from any sharp bends or folds at all times during handling.

When preparing for the stringing of the belt, the crate or container should be aligned to make a straight-line pull from the crate or container directly to the loading zone.

#### 3. Conveyor belt types

There are many types of belting available, consult your bill of materials to determine which type applies to your conveyor.

#### 4. Direction of installation:

The preferred method for stringing the belt is to pull the belt from the tail or horizontal loading section along the conveyor profile in the direction the belt will travel while operating.

It is understood that some conveyors may not permit the preferred loading zone and installation procedure. If feed-in is required from some other point, or if the belt is lowered from above the conveyor, careful individual planning and study is absolutely necessary to ensure the proper installation of conveyor belting. In any case, the basic protection for the belt as outlined in these instructions must still be carefully observed.

It is common on a conventional belt to trim belt edges in the mechanical fastener area. If the belt edge is trimmed at the fastener part of the fastener, (See Fig. # 1) holding ability is reduced and possibly causing fasteners to pull out.

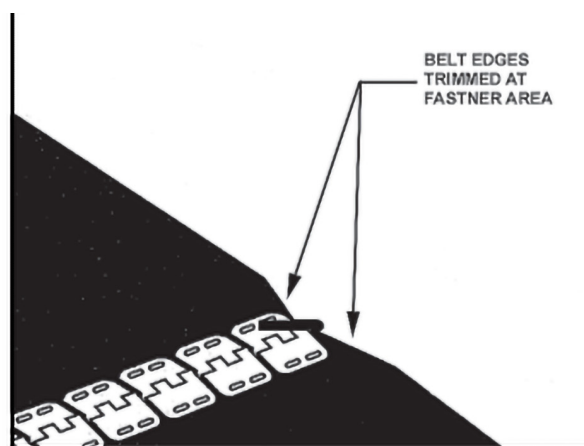

**FIGURE 1: Belt edges trimmed**

#### 5. Handling And Securing Belt During Installation:

There are a number of ways to pull/place the Conveyor belting onto the conveyor:

Method (A) is the most preferred of all those available.

(A.) Thread a rope or cable opposite the direction of belt travel around the rollers and pulleys, then link the rope or cable to the new belt by means of a lead plate or belt clamp to evenly distribute the tension over the width of the belt for drawing the belt into its final position.

(B.) Attach the new belt to the end of the old belt which has been cut for replacement, and use the old belt to pull the new belt into place.

(C.) Pull the belt in place by hand.

Due to the weight and length involved, most belts require the use of a hoisting source such as a crane, hoist, puller, or vehicle with a winch. Additional lifting equipment is advised to aid in the simultaneous lifting and pulling as the belt is gradually drawn from the crate or container to the loading zone and feed-in point onto the conveyor around to its final position ready for splicing. (See Fig. # 2).

The minimum handling equipment should include:

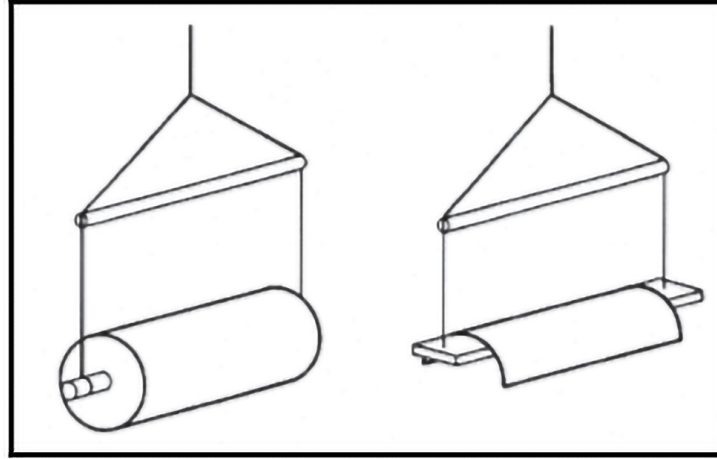

**FIGURE 2. Conveyor belt Lifting devices**

1. One or more cranes, lifting, or hoisting mechanisms.
2. Pulling source.
3. Hoist sling or lifting device with a spreader bar or yoke wider than the belt and a rounded lifting surface as a pulley or rolled plate with a surface radius at least equal to that recommended for the minimum pulley diameters. Both the spreader/yoke and rounded lifting surface should be 6"-12" (150 mm - 300mm) wider than the belt.
4. Lead plate to grasp the leading end of the belt.
5. Holding clamp for providing a positive grip if necessary at midsections of the belt. The holding clamp should be fabricated to straddle the sidewall and have a curved lifting surface like the hoist sling or lifting device.
6. Pulling cable or rope.
7. Feed table and/or support rollers for supporting the weight of the belt to avoid dragging it from the crate or container to the loading zone.

#### 6. Belt splicing

The ends of a conveyor belt can be joined in any conventional manner either with mechanical fasteners or vulcanized splices. (See section 6.2 Maintenance) Mechanical fasteners are very common for final lengths of less than 100 feet (30.5m). For longer belts, vulcanized splicing should be considered.

Vulcanized splice areas can be prepared at the factory for field completion, or splice areas can be simply marked for field reference with an additional pulling "tab" on the belt leading edge for installation assistance. The latter option is always recommended for belts over 100 feet (30.5m) to prevent damage to the prepared lap areas during installation.

Whenever possible, the belt splicing point should be at the lower end of the conveyor. This permits the conveyor structure to support the belt weight and simplifies initial tensioning of the belt.

Rigging for splicing the belt at any elevated point necessitates special belt clamping and lashing provisions. Such arrangements also make it more difficult to pull out excess slack so the start-up setting of the take-up can be more accurately positioned to ensure the belt length finished on the conveyor is equal to the calculated length supplied.

7. Final installation.

A. Install rubber skirting and adjust to desired height.

B. Have a certified Electrician provide power to the unit and install all switches and safety features per the National Electrical Code ANSI / NFPA 70 and local codes. Install an ON/OFF switch for the convenience of the operator.

C. Run unit and track the conveyor belt. (See section service and maintenance).

# Operation

## Operating Safety

1. Read and understand the Operator's Manual and all safety signs before using.
2. Only trained personnel should be allowed to operate the conveyor system. They should have complete knowledge of conveyor operation, electrical controls, safety and warning devices, and the capacity and performance limitations of the system.
3. Disconnect and disable electrical supply completely and wait for all moving parts to stop before servicing, adjusting, repairing or unplugging.
4. Clear the area of bystanders, especially children, before starting.
5. Keep hands, feet, hair and loose clothing away from all moving and/or rotating parts.
6. Do not operate machine when any guards are removed.
7. No person should be allowed to ride on, or cross over a moving conveyor. Personnel must use walkways, stairs, ladders, and crossovers provided.
8. Be aware of the hazards of the type of material that is being conveyed. Some materials contain explosive dust. See table at back of manual.
9. Review safety related items annually with all personnel who will be operating or maintaining the conveyor.
10. At no time should the conveyors be used to handle material other than that originally specified. Capacity and belt speed design ratings should not be exceeded.
11. Conveyor covers can become slippery. Do not Step, Stand, Climb or Walk on conveyor covers. Serious Injury or death can occur from Stepping, Standing, Climbing or Walking on conveyor covers. Top covers are not designed to withstand a load.
12. Good housekeeping is a prerequisite for safe conditions. All areas around a conveyor, and particularly those surrounding drives, walkways, safety devices, and control stations, should be kept free of debris and obstacles.
13. Good lighting contributes to a safe working environment.

## To the new operator or owner

The Chief Spool Enclosed Belt conveyors are designed to efficiently move granular material from location to location. Power is provided by an electric motor. Be familiar with the machine before starting.

It is the responsibility of the owner or operator to read this manual and to train all other operators before they start working with the machine. In addition to the design and configuration of equipment, hazard control and accident prevention are dependent upon the awareness, concern, and prudence of personnel involved in the operation, transport, maintenance and storage of equipment or in the use and maintenance of facilities. Follow all safety instructions exactly.

Safety is everyone's business. By following recommended procedures, a safe working environment is provided for the operator, bystanders and the area around the work-site. Untrained operators are not qualified to operate the machine.

Many features incorporated into this machine are the result of suggestions made by customers like you. Read this manual carefully to learn how to operate the machine safely and how to set it to provide maximum efficiency. By following the operating instructions in conjunction with a good maintenance program, your conveyor will provide many years of trouble-free service.

## Machine Components

The Chief Spool Enclosed Belt conveyor is an endless belt that travels around a series of rollers enclosed in a frame for moving grain or, almost any granular product. Each machine can consist of a single or multi-segmented frame to fit the application requirements. The machine can be mounted in a variety of ways but sufficient support must be provided under or over the frame to prevent sagging or deflection.

An electric motor provides power at the discharge end of the conveyor. It can be attached to:

1. A right angle gearbox that drives a roller chain to provide power to the head pulley.
2. A shaft mount gear reducer that is powered by a V-belt which drives the head pulley directly.

### CHIEF SPOOL ENCLOSED BELT CONVEYOR MACHINE COMPONENTS

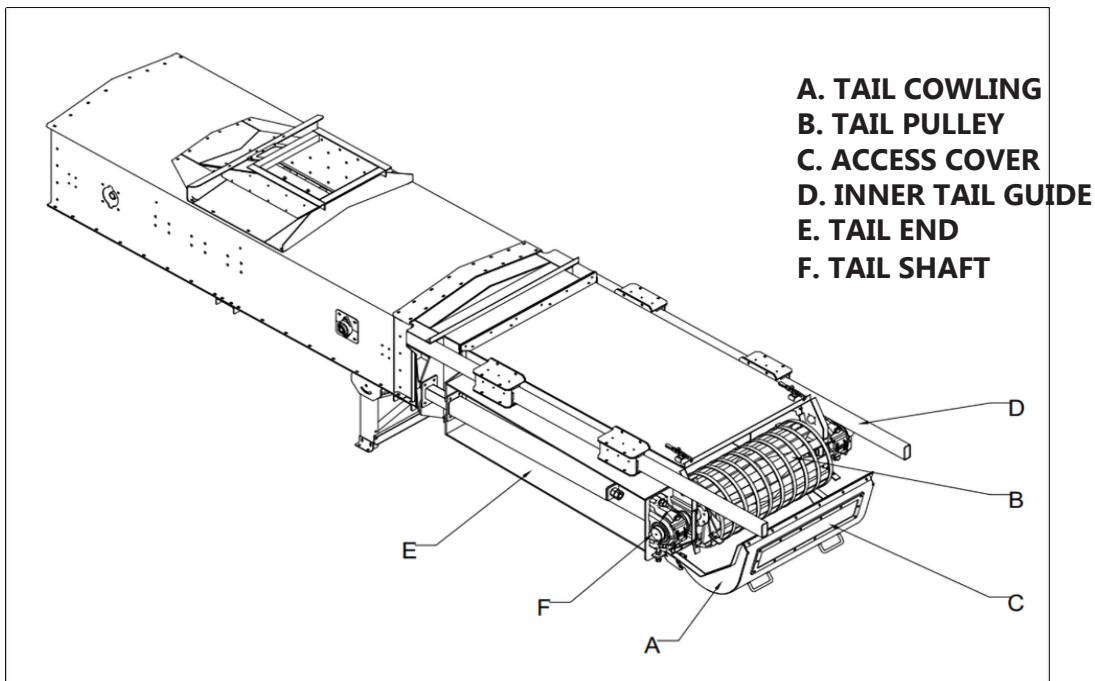

Machine Components (contd.)

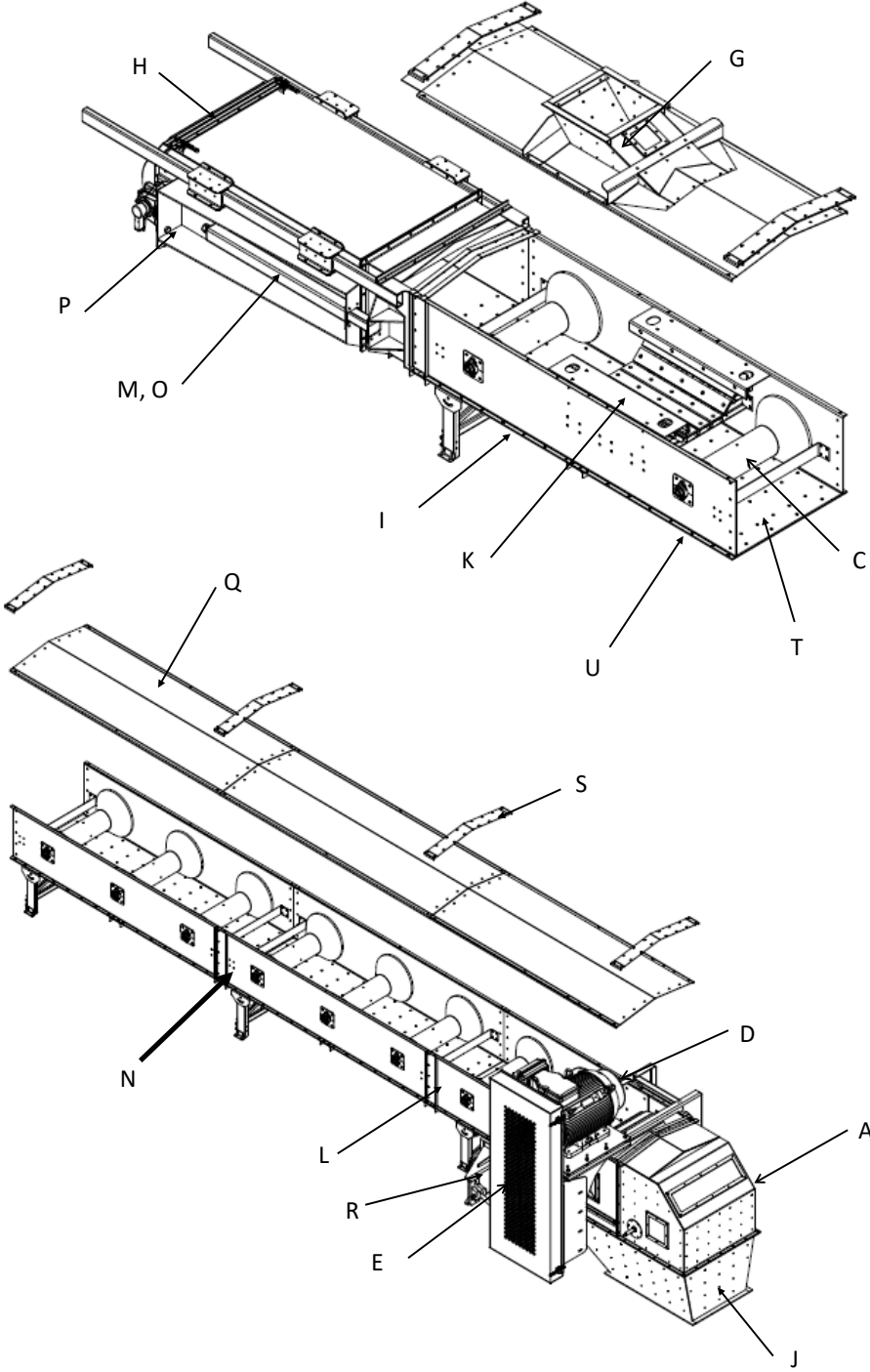

- A. HEAD PULLEY
- B. TAIL PULLEY (NOT SHOW, SEE PREVIOUS PAGE)
- C. SPOOL ROLLERS
- D. ELECTRIC MOTOR
- E. SHAFT GEAR MOUNT REDUCER
- F. CONVEYOR BELT
- G. FLANGE INLET
- H. TAIL END
- I. ENCLOSED FRAME
- J. LOWER DISCHARGE
- K. SKIRT BOARD
- L. SPLICE
- M. TAKE-UP
- N. INSPECTION WINDOW
- O. CONVEYOR BELT TENSION ADJUSTMENT
- P. CONVEYOR BELT ALIGNMENT ADJUSTMENT
- Q. TOP COVERS
- R. TORQUE BRACKET (DEPENDS ON DRIVE TYPE, NOT SHOWN)
- S. SPLICE COVER
- T. UHMW BOTTOM CLEAT
- U. BOTTOM COVERS



## Pre-Operation Checklist

Efficient and safe operation of the Chief Spool Enclosed Belt conveyor requires that each operator reads and understands the operating procedures and all related safety precautions outlined in this section. A pre-operation checklist is provided for the operator. It is important for both the personal safety and maintaining the good mechanical condition of the conveyor that this checklist is followed.

Before operating the conveyor and each time thereafter, the following areas should be checked off:

1. Service the machine per the schedule outlined in (Section Service and Maintenance).
2. Use only an electric motor of adequate power to operate the machine.
3. If the material conveyed is explosive or dust accumulation can create a hazardous condition, totally enclosed, explosion proof motors must be used. These carry Underwriter's Laboratories, Inc. labels. The two common labels are Class II, Group F (for use in areas containing carbon black, coal, and coke dusts), and Class II, Group G (for use in areas containing grain dusts).
4. Check that all guards are installed, secured and functioning as intended. Do not operate with missing or damaged shields.
5. Check work-site. Clean up working area to prevent slipping or tripping.
6. Check that the drive belt, roller chain and conveying belt are not frayed or damaged and that they are properly adjusted and aligned.
7. Be sure the conveyor is securely mounted or attached to its supports.
8. Check that the discharge and intake areas are free of obstructions.
9. Check that the conveying belt is loose and can move or turn freely.

## Machine Break-In

Although there are no operational restrictions on the conveyor when used for the first time, it is recommended that the following mechanical items be checked:

### A. Before starting:

1. Read the conveyor Operator's Manuals.
2. Re-torque all fasteners and hardware.
3. During the conveyors first few minutes of operation, check conveying belt alignment to be sure that the belt is properly aligned.
4. Check that all safety signs are installed and legible. Apply new signs if required.

### B. After operating for 1/2 hour:

1. Re-torque all fasteners and hardware.
2. Check the drive belt or roller chain tension and alignment. Adjust tension or alignment as required.
3. Check the conveying belt tension and alignment. Adjust tension or alignment as required.
4. Check the oil level in the gearbox (if applicable).
5. Check that all guards are installed and working as intended.

### C. After operating for 5 hours and 10 hours:

1. Re-torque all fasteners and hardware.
2. Check that all guards are installed and are working properly.
3. Check safety signs. Install new ones if required.
4. Check the drive belt, roller chain and conveying belt tension and alignment. Adjust tension or alignment as required.
5. Check the oil level in the gearbox (if applicable).

### D. After operating for 10 hours:

6. Next, proceed to the normal servicing and maintenance schedule as defined in the Maintenance Section.

## Controls

Before starting to work, all operators should familiarize themselves with the location and function of the controls.

### 1. Electric Drive:

Have a licensed electrician provide power to the machine per the National Electrical Code ANSI / NFPA 70 and local codes. Install an ON/OFF switch for the convenience of the operator.

### 2. Conveying System:

The conveyor works well as a component or segment of a conveying system. In that instance, the power switches may be part of a master control system for turning the entire system on and off. It is recommended that a licensed electrician provide power to the master control system per the applicable local and national electrical codes. Each customer must provide a means of bringing material to the input end of the conveyor and removing it from the discharge end. Arrange the conveying and control systems to fit the application.

## Safety Devices

Conveyor systems should incorporate electrical safety devices to accommodate protection of operating personnel, as well as to protect damage to the mechanical parts of the conveyor. The most common devices are listed below. All devices listed below are optional equipment which may or may not be available from Chief Industries Inc.

### 1. Chute-Level Switches

Some transfer points and certain materials dictate the use of chute-level switches. These are intended to operate when the chute becomes nearly plugged, and are arranged to shut down the conveyor discharging to the chute. Similar switches are used in hoppers, bins, and below the discharge points of stackers.

### 2. Side-Slip Switches.

On long conveyors or where belt training can be a problem, special limit switches are used to detect belt misalignment. These switches can be arranged to shut down the belt or to sound an alarm.

### 3. Emergency Stop Switches.

Full-cord switches are located along the walkway side (or sides) of conveyors, and are intended for emergency use. Maintained-contact type switches are preferred to prevent accidental restart of the conveyor. These switches require manual reset to make the motor control circuit operable.

### 4. Travel Limit Switches.

Conveying equipment moving during normal operation requires end-travel and over-travel limit switches to maintain such movement within safe limits. Examples of this type of equipment include trippers, shuttle conveyors, and stackers.

### 5. Warning Horns.

Audible devices are normally used to warn operating personnel that the conveyor system is being placed in operation or that equipment is in the travel mode.

### 6. Closed-Circuit Television.

A control center can employ television monitors to overlook a complex and extended belt conveyor system.

### 7. Control Centers.

A master control center and console which provides for efficient operation of belt conveyor systems. Master Control Centers can be applied to manage, monitor, optimize and record performance of large complex conveying systems.

### 8. Programmable Controllers.

A programmable controller (PC) can be installed to automate and control repetitive tasks and functions.

## Operating

When using the conveyor, follow this procedure:

1. Clear the area of bystanders before starting.
2. Review the Pre-Operation Checklist (Pre-operation checklist) before starting.
3. Keep all spectators and bystanders out of the working and machine area. Should anyone enter this area, stop the machine immediately.
4. Be sure a certified electrician is used to insure power and shutdown switches are conveniently positioned for the operator.
5. Check that all guards are in place and working as intended.
6. Check drive belt, roller chain and conveying belt tension and alignment. There may be rapid decrease in belt tension during the first few hours of operation until the belts have run in. The correct operating tension is the lowest tension at which the belts will not slip under peak load conditions.
7. Start the system or conveying system that removes material from the conveyor.
8. Starting:
  - A. Turn the electric motor ON.
  - B. Start the flow of material.
9. Stopping:
  - A. Run until the conveying belt is empty.
  - B. Turn off motor and lock out power source.
10. Emergency Stopping:

Although it is recommended that the conveying belt be emptied before stopping, in an emergency situation, stop or shutdown the power source immediately. Correct the emergency before resuming work.

### 11. Restarting:

When the machine is shut down inadvertently or for an emergency, the conveying belt may still be covered with material. Since the start-up torque loads are much higher than normal when the belt is covered, it may be necessary to tighten the drive belt slightly to handle the heavier than normal loads. Refer to section (Primary drive belt tension and alignment) in the maintenance section of this manual.

## IMPORTANT

Remember to loosen the primary drive belt to the correct tension after discharging all of the material from the conveying belt. Refer to section (Primary drive belt tension and alignment) in the maintenance section of this manual.



## WARNING

Place all controls in neutral or off, stop the motor, and wait for all moving parts to stop. Then disable power source before servicing, adjusting, repairing, or unplugging. Failure to heed may result in personal injury or death.

**12. Belt Speed:**

See Recommended Maximum Belt Speeds table, Maximum belt speeds, or contact the factory with the appropriate drive components to obtain the recommended belt speed.

**13. Operating Hints:**

A. Always listen for any unusual sounds or noises. If any are heard, stop the machine and determine the source. Correct the problem before resuming work.

B. Never allow anyone into the workplace hazard area.

If anyone enters, stop immediately. Make them LEAVE before resuming work.

C. Do not run the machine for long periods of time with no material on the belt. It increases the wear. Try to run only when moving material.

**Conveyor Loading And Discharge**

The successful operation of a belt conveyor requires: first, that the conveyor belt be loaded properly; second, that the material carried by the belt be discharged properly. These two requirements are very important and must be given most careful consideration if the belt conveyor is to function as intended.

**Loading The Belt**

While the loading of material onto a belt conveyor involves many considerations, of prime importance is the loading of the material centrally on the belt so that the material velocity in the direction of belt travel is, as nearly as equal to the velocity of the conveyor belt itself.

If the material isn't delivered onto the belt at the belt speed, there will be a turbulence in the mass of material at the loading point. A build-up in volume may form at this point. Provided that the material is delivered centrally onto the belt, the ideal loading is attained when the forward velocity in the direction of the belt is exactly the same as the velocity of the belt. When this condition exists, there is minimum wear on the belt cover, minimum power is required to operate the belt, the material takes the proper load shape quietly without spillage, and the minimum degradation or dusting of the material is assured. While this ideal condition is difficult to reach in actual practice, it is well worth the effort to attain it as closely as possible.

**Loading Chutes**

The loading chute must be inclined in order to give the material flow a desirable forward velocity. If the material is fine and contains some moisture, the chute must be made steep enough so that the material will slide rapidly. However, if the material is lumpy, the steepness of the chute is limited to that angle at which the material will slide satisfactorily, but not bounce and tumble. High lump velocities may be controlled by the use of baffle bars or chains hung in the path of the lumps.

Multiple angle chutes, curved chutes, and sometimes covered chutes can be employed to impart a uniform sliding action to the material. If sufficient velocity cannot be imparted to the material and in the proper direction—it may be necessary to reduce the speed of the receiving belt conveyor. This is done to obtain the minimum difference between the forward velocity of the material flow and the belt velocity. However, such a compromise may result in a wider, more costly belt.

Loading chutes can be made of metal or other materials. Metal chutes are the most common. For abrasive materials, the chute can be lined with abrasion-resisting, removable plates or other material such as ceramic liners. For corrosive materials, corrosion-resistant metal coatings, rubbers, synthetics, or fused-on glass linings can be used.

**Width of Loading Chutes.** The width of a loading chute should be no greater than two-thirds the width of the receiving belt. On the other hand, the inside width of the loading chute should be at least two and a half to three times the largest dimension of uniformly sized lumps, when they represent a considerable percentage of the material flow. Where lumps and fines are mixed, the inside width of the chute may be made two times the maximum lump size. These proportions are essential to the proper loading of the belt and to the prevention of interlocking and jamming of lumps in the chute.

**Skirtboards**

To retain the material on the belt, after it leaves the loading chute and until it reaches belt speed, skirtboards are necessary. These skirtboards usually are an extension of the sides of the loading chute and extend parallel to one another for some distance along the conveyor belt. The skirtboards normally are made of metal. The lower edge of the skirtboards are positioned some distance above the belt. The gap between the skirtboard bottom edge and the belt surface is sealed by a rectangular rubber strip, attached or clamped to the skirtboard. Figure (# 24 & # 25) show typical skirtboard arrangements for flat and troughed belts.

If the material conveyed contains hard lumps, particularly lumps with sharp edges, the gap between the bottom of the skirtboards and the belt should be made to increase uniformly in the direction of belt travel. Any lump forced under the skirtboard edge will quickly free itself as the belt moves forward, and thus not abrade the belt.

When handling a mixture of large lumps and fines or only sized lumps, the skirtboards sometimes are not made parallel to each other but are splayed outward in the direction of the belt travel. Such an arrangement prevents lumps from jamming between the skirtboards.

Commonly used proportions and details of skirtboards and rubber strip edgings are as follows:

**Spacing of Skirtboards.** The maximum distance between skirtboards customarily is two-thirds the width of a troughed belt, (0.666b). However, it is desirable, when possible, to reduce this spacing to one-half the width of the troughed belt (0.500b), especially for free-flowing materials, such as grain. (See section SKIRTBOARD HEIGHT & WIDTHS).

**Skirtboard Rubber Edging.** Adjustment of Rubber skirtboard edging should be adjusted frequently so that the edging just touches the belt surface. Forcing the edging hard against the belt cover will not only groove the belt cover but also require additional power to move the belt. On conveyors with continuous skirtboards, improper pressure of rubber skirtboard edging may overload the belt conveyor driving motor. (See the maintenance section of this manual for detailed information on adjusting the skirtboards).

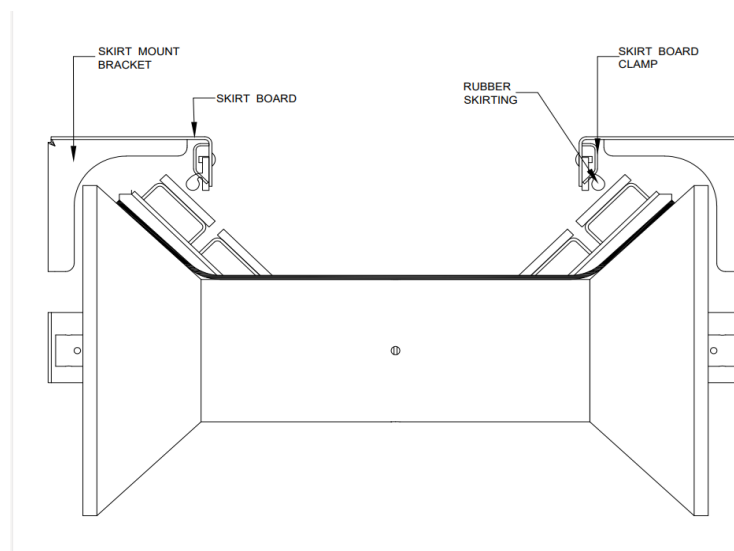

*Typical application of skirtboard on trough belt.*

## Discharge Chutes

Materials carried by a belt conveyor can be discharged from the belt in a variety of different ways to effect desired results. The discharge can be accomplished at a definite point or points, or it can extend alongside the belt conveyor, on one or both sides, for considerable distances. The flexibility of discharge arrangements of belt conveyors facilitates their use in the maximum fill of long bins and in the creation of large and variously shaped storage piles.

The simplest method of discharge from a conveyor belt is to let the material pass over a head pulley and fall into a pile. By adding a suitable chute, the discharge can be directed, as desired, to a pile, a bin, or another conveyor. Whenever the material is discharged over an end pulley, the speed of the belt and the diameter of the end pulley are factors which determine the path of the discharged material. This path is called the trajectory.

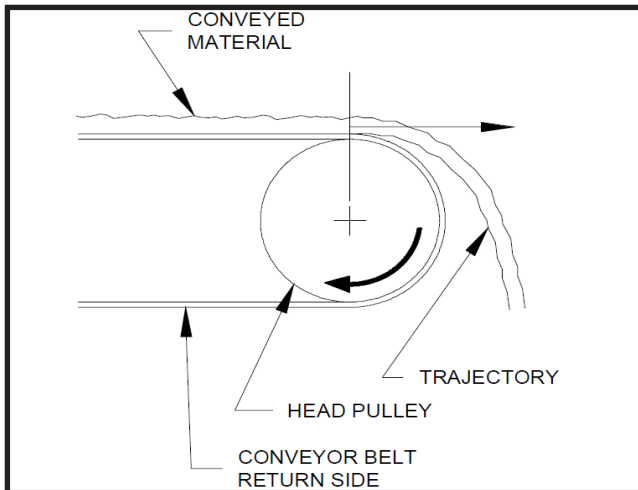

*When the belt speed is sufficiently high, the material leaves the belt at the tangency of the belt and pulley (approx. 2:00 o'clock)*

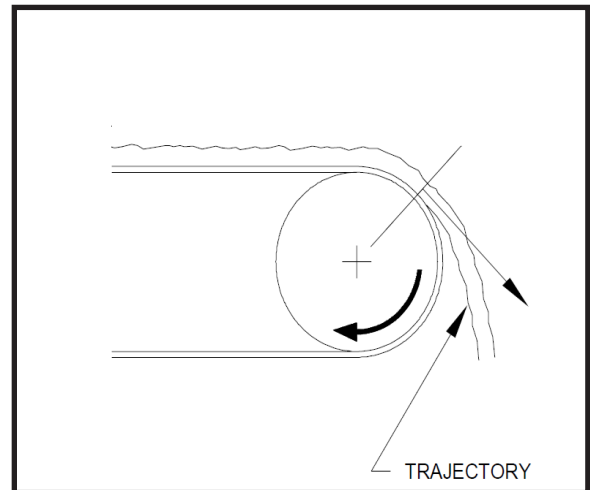

*When the belt speed is run at a lower speed, the material will follow part way around the head pulley*

The prime requirement of implementing a discharge is that the chute collect all the material discharged and all material is cleaned from the conveyor belt as it leaves the discharge area. The carrying surface of the belt should be free from any adhering material as it passes back over the rollers. Some materials will partly free from the surface of the belt as the belt flexes in passing over the head pulley. Other materials may adhere to the conveyor belt. For more about belt cleaning devices see (Section Skirtboard Height & Widths).

### Belt Cleaning Devices

Many materials conveyed on belts are sticky. Portions cling to the conveying surface of the belt and are not discharged with the rest of the material at the discharge points. Material is carried back on the return run, where it may cause excessive wear, build-up on rollers, misalignment of the belt, and possible damage by forcing the belt against some part of the supporting structure. The material that is carried back on the return run eventually drops off the belt, causing maintenance and housekeeping problems. It is, therefore, desirable to clean the belt before it contacts any snub pulleys or rollers.

Materials which will stick to the belt usually will stick to any snub pulleys which contact the dirty side of the belt. Therefore, pulley-cleaning devices may be as necessary as the belt cleaners.

There are several types of belt cleaners. Selecting one which should be used for a particular material is difficult, since such factors as temperature, moisture content, material size, etc. vary with each application. Because these factors determine the effectiveness of the cleaning device, each job requires individual consideration. Even after a belt cleaner is installed, adjustments will be required on the job to meet the characteristics of the material. Sometimes, more than one belt cleaner is required.

Belt cleaning is simplified by the use of vulcanized splices, especially with those cleaning devices which employ blades in contact with the belt surface. Improperly installed mechanical fasteners can catch on cleaning devices and cause them to jump and vibrate. Recessed mechanical fasteners will help minimize this problem. Proper maintenance and adjustment of the belt cleaner will help prevent belt damage, reduce wear on the belt and cleaner blades, and assure efficient cleaning action.

#### Types of Belt Cleaners

**Single- or Multiple-Blade Belt Scrapers.** These are designed for scraping material from the belt surface. One or more blades are held in contact with the belt surface by counterweight or spring tension. A single-blade scraper consists of one blade across the width of the belt. A multiple-blade scraper consists of two or more parallel blades across the width of the belt.

A scraper blade can be made from any one of several materials. A combination of materials sometimes is used on multiple-blade scrapers to improve cleaning results. For example, a rubber blade and a special steel blade may be used in combination.

Strips of belting should not be used for scraper blades because fine particles of the material being handled on the conveyor may become embed

## LOCATION OF BELT CLEANER

The belt cleaner should be located so that the material which is removed from the belt can fall into the discharge chute or can be collected for practical disposal. Single or multiple blade scrapers, with spring or counterweighted construction, should be located at points around the contact surface of belt and pulley or immediately after the belt leaves the pulley.

Design of the discharge chute often determines the specific location. The rotary blade cleaner is usually located behind the point where the belt breaks contact with the pulley, as illustrated in (Fig. # 3) The rotary brush cleaner should be located as described for the rotary blade cleaner. However, if necessary for reasons of chute design, snub pulley location, etc., the rotary brush can also be positioned to brush the belt clean while the belt is still in contact with the pulley as shown in (Fig. # 4).

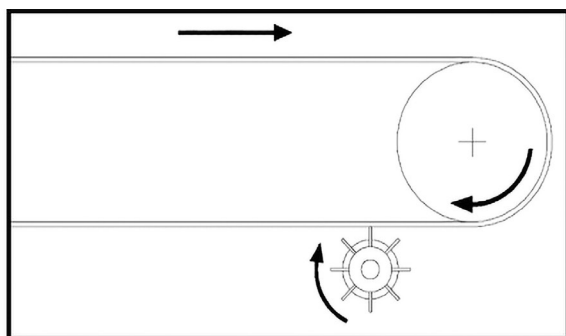

FIGURE 3. Belt cleaner behind head pulley

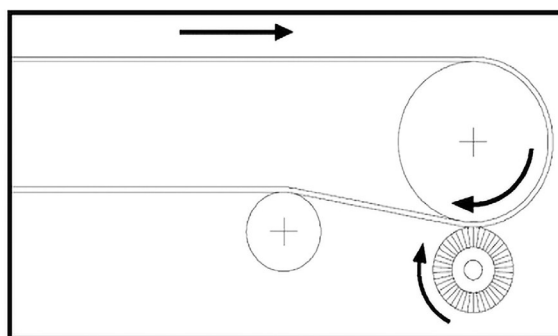

FIGURE 4. Belt cleaner at point of contact with pulley

## Optional Equipment

1. Optional Equipment:

Angle flanged inlet:

Angle flanged inlet opening complete with rubber skirting. Inlet directs product flow onto belt to maintain capacity and reduce spillage.

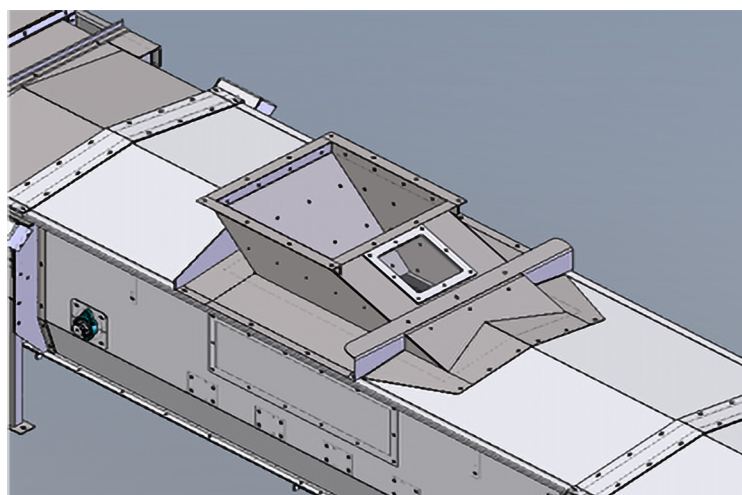

**Optional angle flanged inlet**

### Zero Speed Switch:

The Zero Speed Switch detects the absence or presence of rotational motion. This non-contacting unit provides cost effective equipment protection even in the harshest conditions. Typical applications include tail pulley shafts, driven pulleys, motor shaft sensing. Zero Speed Switches are designed to activate an alarm system and/or initiate a control action to prevent downtime of machinery. Zero Speed Switches provide protection from speed related damage including broken belts, overloads or belt slippage.

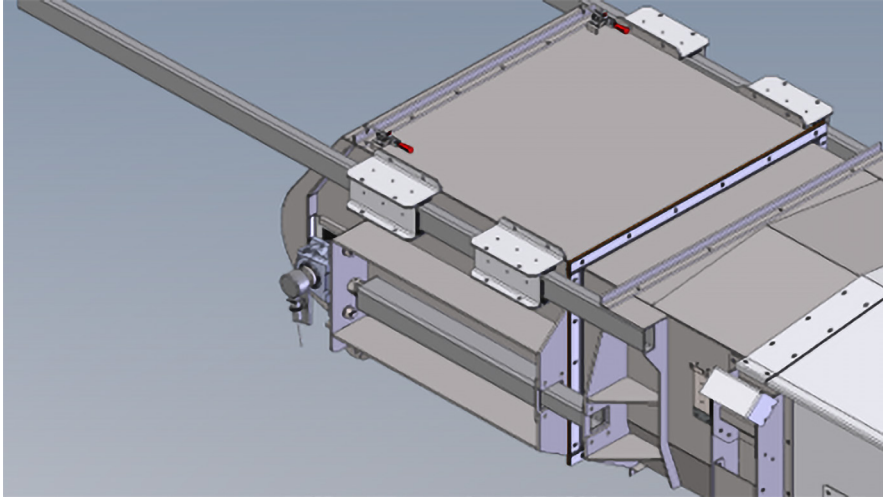

Zero Speed Switch is used to sense rotation of the tail pulley on a Chief Spool Enclosed Belt Conveyor.

### Belt Misalignment Switch:

The Belt Misalignment switch is an electronic limit switch. When a belt misaligns or a pulley moves over and contacts the sensor, the built in solid-state electronic circuitry detects the lateral force of the belt or pulley and activates a voltage free relay contact. This relay contact is used to immediately alarm and shutdown the machine. The face of the sensor is made from hardened stainless steel, so that there is virtually no wear when a belt contacts it. The sensor is not affected by dust or material build up and will still work when completely covered by material. Sensors are normally installed in pairs on opposite sides of the machine. Usually a pair of sensors at each pulley is used, but additional pairs can be installed as required. An external test knob allows for quick and simple sensor / system testing.

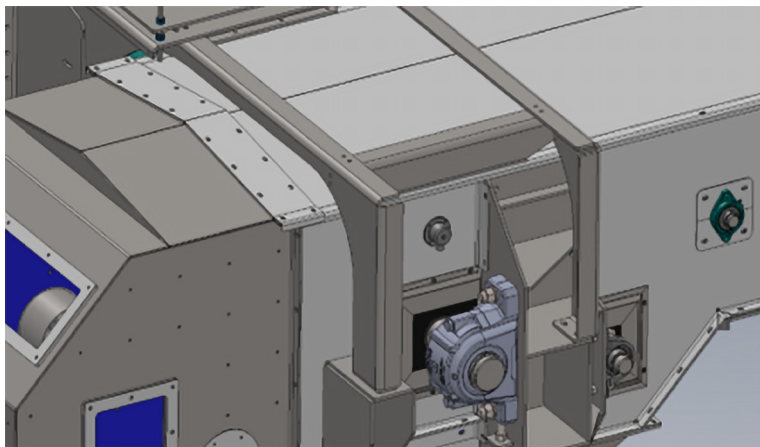

Belt Misalignment Switch is used to sense when a belt misaligns or a pulley moves over and contacts the sensor.



**Level Indicator Switch:**

A Level Indicator Switch detects level or plug situations for bulk granular solids or liquids and is used as a plug or choke detector in a Chief belt conveyor. The sensor is fully encapsulated in a 30 mm diameter nylon body that is corrosion and abrasion resistant, dust-tight and waterproof. The Level Indicator Switch operates by detecting capacitance change when material is present. A user selectable relay output can be magnetically calibrated to be normally energized or de-energized, and during calibration the sensor automatically compensates for material build up, shields or attached metal probes.

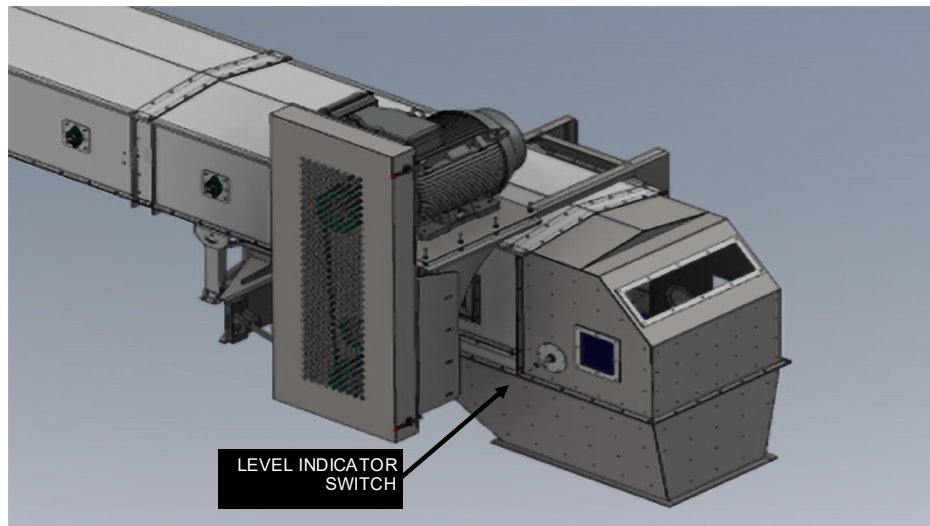

Level Indicator Switch is used to detect plug or choke in a Chief belt conveyor.

# Service And Maintenance



## MAINTENANCE SAFETY

1. Review the Operator's Manual and all safety items before working with, maintaining or operating the conveyor.
2. Place all controls in neutral or off, stop motor, disable power source and wait for all moving parts to stop before servicing, adjusting, repairing or unplugging.
3. Follow good shop practices:
  - Keep service area clean and dry.
  - Be sure electrical outlets and tools are properly grounded.
  - Use adequate light for the job at hand.
4. Keep hands, feet, hair and clothing away from all moving and/or rotating parts.
5. Clear the area of bystanders, especially children, when carrying out any maintenance and repairs or making any adjustments.
6. Before resuming work, install and secure all guards when maintenance work is completed.
7. Do not Step, Stand, Climb or Walk on conveyor covers. Serious Injury Or Death can occur from Stepping, Standing, Climbing or Walking on conveyor covers. Conveyor covers can become slippery. Top covers are not designed to withstand a load.
8. Keep safety signs clean. Replace any sign that is damaged or not clearly visible.
9. Remove only one guard, cover, or hatch at a time, and replace it as soon as you are done inspecting or servicing the conveyor.
10. Do not poke anything into the conveyor to clear a jam.

## Service

Along with a servicing interval, a visual inspection should also be performed. Maintenance personnel can often detect potential problems from any unusual sounds made by such components as shafts, bearings and drives.

## Fluids and Lubricants

### 1. Gearbox Lube

Use Mobilube HD SAE 80W-90 Gear lube or equivalent with the following specifications:

API Service GL-5

MIL-L-2105D

MACK GO-H

### 2. Use a spray chain lubricant or SAE 30 engine oil.

Stamped on chain link side plate.

CHAIN TYPE	AMBIENT TEMPERATURE RANGE		
	14°F - 32°F	32°F - 104°F	104°F - 122°F
RS-50 -	SAE 10	SAE 20	SAE 30
RS-60 / RS-80	SAE 20	SAE 30	SAE 30
RS-100	SAE 20	SAE 30	SAE 30
RS120 / MORE	SAE 30	SAE 40	SAE 40

### 3. Storing Lubricants

Your machine can operate at top efficiency only if clean lubricants are used. Use clean containers to handle all lubricants. Store them in an area protected from dust, moisture and other contaminants.

## Greasing

Use the Maintenance Checklist provided to keep a record of all scheduled maintenance.

1. Use a hand-held grease gun for all greasing.
2. Wipe grease fitting with a clean cloth before greasing, to avoid injecting dirt and grit.
3. Replace and repair broken fittings immediately.
4. If fittings will not take grease, remove and clean thoroughly. Also clean lubricant passageway. Replace fitting if necessary.
5. Grease

Use an SAE multi-purpose high temperature grease with extreme pressure (EP) performance meeting or exceeding the NLGI #2 rating for all requirements. Also acceptable is an SAE multi-purpose lithium based grease.

 **MAINTENANCE SAFETY**

Place all controls in neutral or off, stop the motor, and wait for all moving parts to stop. Then disable power source before servicing, adjusting, repairing, or unplugging.

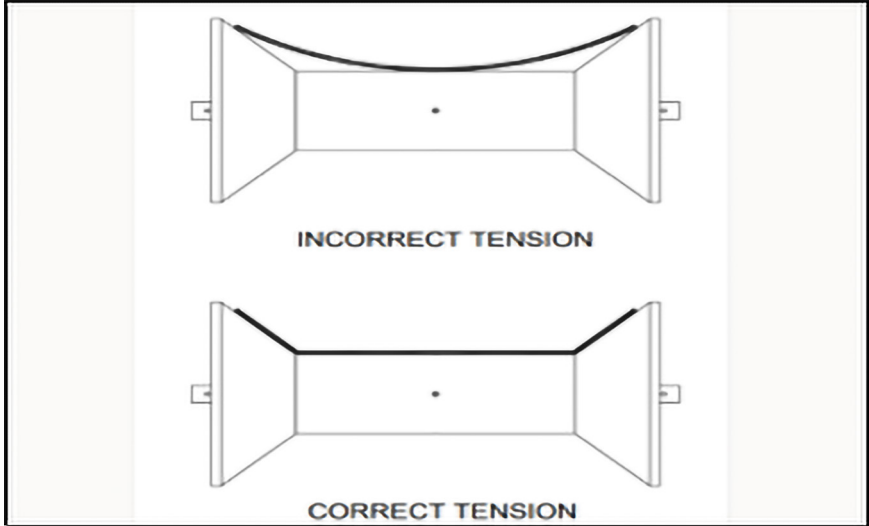

*Check conveyor tension*

**NOTE**

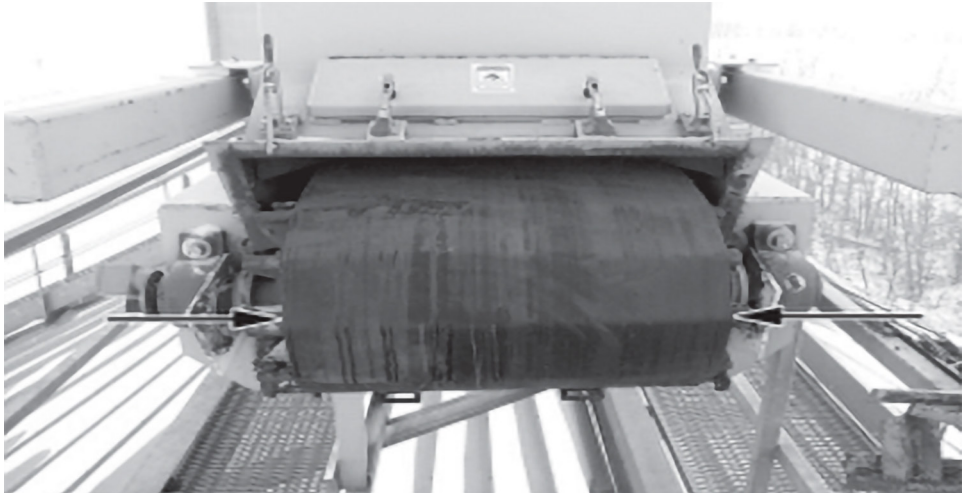

**40 Hours or Weekly****WARNING**

Never lubricate while the machine is running! Shut machine off, wait for all moving parts to stop, and lock out power before adjusting or servicing. Failure to heed may result in personal injury or death.

1. Lubricate all pillow block bearings, all locations. Do not over grease.



Grease pillow block bearings



Grease pillow block bearings

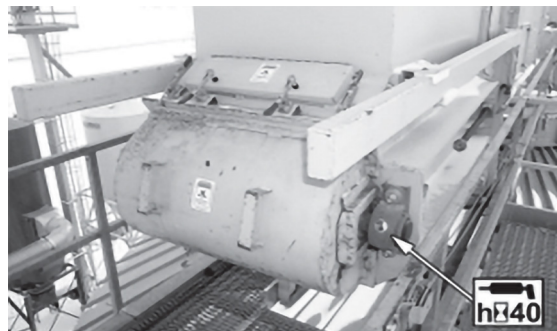

Grease pillow block bearings

2. Check for excessive component wear.

Check all moving parts such components as rollers, pulleys, shafts, bearings, drives, belts and belt splices. Complete a "Walking inspection" of the entire conveyor. (See section General Maintenance Practices).

**100 HOURS**

1. Check gearbox oil level.

**WARNING**

Place all controls in neutral or off, stop the motor, and wait for all moving parts to stop. Then disable power source before servicing, adjusting, repairing, or unplugging. Failure to heed may result in personal injury or

## 40 Hours or Weekly (contd.)

**WARNING**

Place all controls in neutral or off, stop the motor, and wait for all moving parts to stop. Then disable power source before servicing, adjusting, repairing, or plugging. Failure to heed may result in personal injury or death

2. Check and adjust (if necessary), the tension and alignment of the primary drive belts.

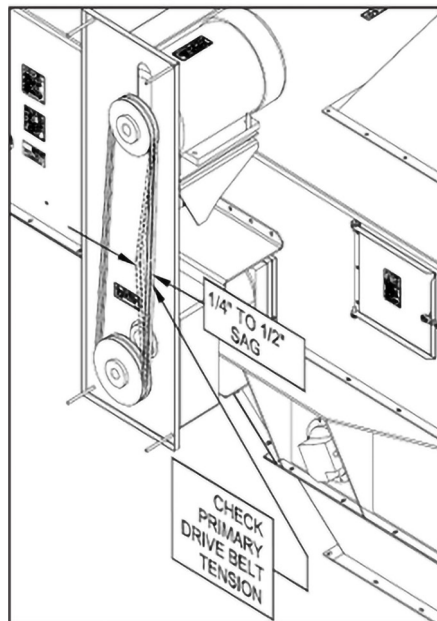

*Check the primary drive belt tension by pushing on center span of belts 5-10 lbs. Belt sag should be 1/4\" to 1/2\"*

3. Check and adjust (if necessary), the tension and alignment of the primary drive belts.

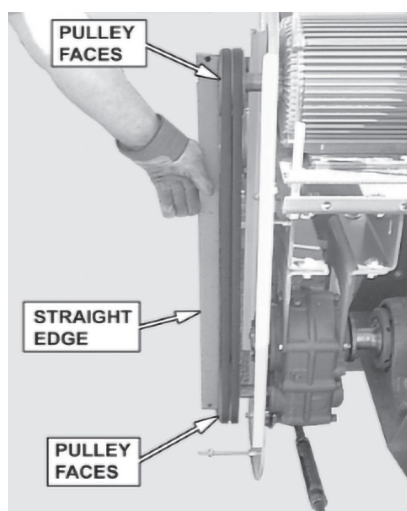

4. Check for excessive components wear.

Check all moving parts such components as rollers, pulleys, shafts, bearings, drives, belts and belt splices. Complete a "Walking inspection" of the entire conveyor.

### 100 HOURS

1. Check gearbox oil level.

## WARNING

Place all controls in neutral or off, stop the motor, and wait for all moving parts to stop. Then disable power source before servicing, adjusting, repairing, or plugging. Failure to heed may result in personal injury or death

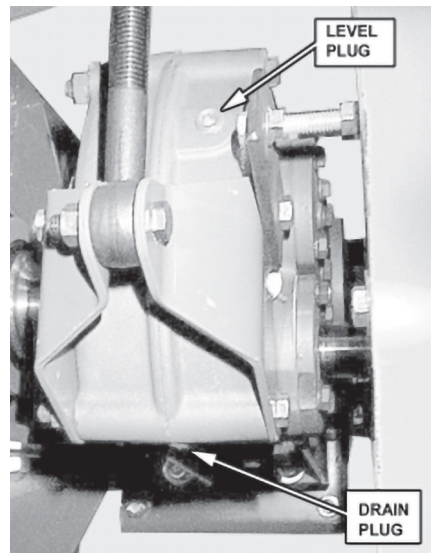

*Check gearbox oil*

2. Check the conveyor belt splice.

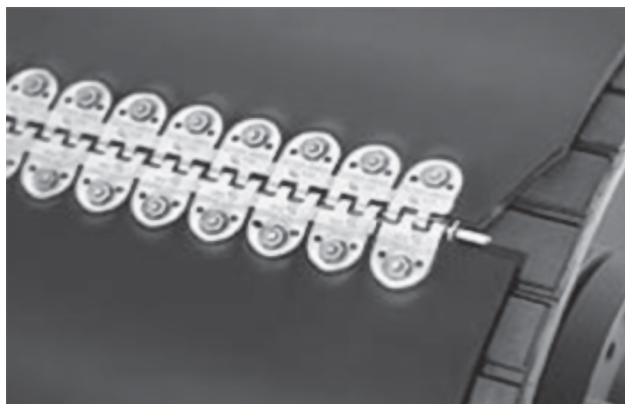

**200 Hours**

1. Check gearbox breather.

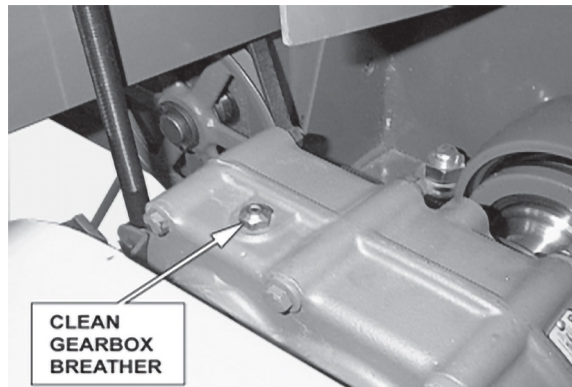
**BI-ANNUALLY**

1. Change gearbox oil.
2. Check the condition of weather seals on all access covers and function of top covers to make sure that the conveyor is kept free of moisture.

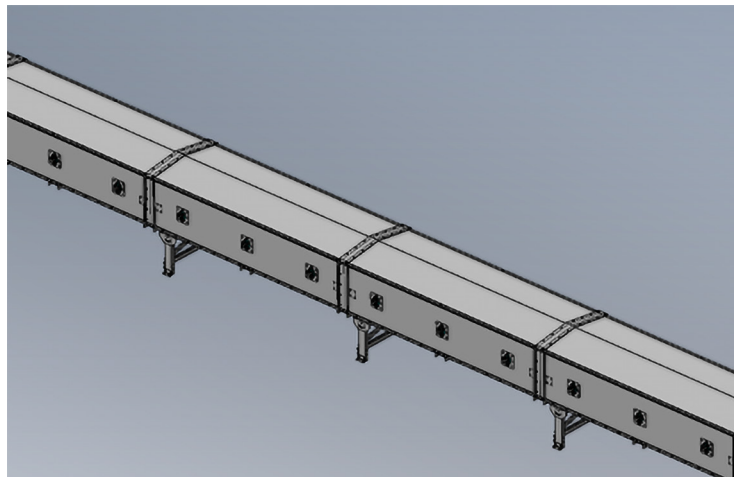



**Service Record**

See Lubrication and Maintenance sections for details of service. Copy this page to continue record.

ACTION CODE:   √ CHECK                   CL CLEAN  
                           L LUBRICATE                C CHANGE

MAINTENANCE	HOURS													
	SERVICED BY													
<b>8 HOURS OR DAILY</b>														
√ CONVEYOR BELT TENSION														
√ CONVEYOR BELT ALIGNMENT														
<b>40 HOURS</b>														
L PILLOW BLOCK BEARINGS (ALL LOCATIONS)														
√ TENSION AND ALIGNMENT OF PRIMARY DRIVE BELTS														
√ FOR EXCESSIVE COMPONENT WEAR														
<b>100 HOURS</b>														
√ GEARBOX OIL LEVEL														
√ CONDITION OF BELT SPLICE														
<b>200 HOURS</b>														
CL GEARBOX BREATHER														
<b>BI-ANNUALLY</b>														
C GEARBOX OIL														
√ CONDITION OF WEATHER SEALS AND SEALING COMPONENTS														

## Maintenance

By following a careful service and maintenance program for your machine, you will enjoy many years of trouble-free service.

### General Maintenance Practices

Along with a servicing interval. A “walking inspection” of a belt conveyor system is a good means by which well-trained maintenance personnel can often detect potential problems from any unusual sounds made by such components as rollers, pulleys, shafts, bearings, drives, belts and belt splices.

The following list covers items you should check as you inspect your conveyor.

## WARNING

Place all controls in neutral or off, stop the motor, and wait for all moving parts to stop. Then disable power source before servicing, adjusting, repairing, or unplugging. Failure to heed may result in personal injury or death.

1. **Spillage:** Check if material is leaking or spilling anywhere in the system.
2. **Sounds:** Walk the length of the conveyor as it operates and listen for unusual sounds. Such sounds can be an early sign of trouble with your conveyor components.
3. **Weather-tightness:** Check that a conveyor installed outdoors is sealed against weather and moisture. Excess moisture is trouble, whether inside or outside the unit.
4. **Rust or corrosion:** Look for rust and corrosion on the conveyor. If you find some, take care of it now! Repair and paint over it immediately.
5. **Set screws:** Check set screws for tightness. Paint them orange so they're easy to spot during conveyor inspections. As simple as this seems, loose set screws are a common problem source for conveyors.
6. **Tension:** Check every item on the conveyor that requires tensioning, including V-belts, chains, and conveying belts. Loose tension can lead to several operating problems and damage the conveyor components.
7. **Bearings, reducers, and drive components:** Any moving parts and those related to the conveyor drive, including bearings, reducers, and other components, are real hot spots for problems. Inspect lubrication levels and, per the manufacturer's specifications, check for problems including high temperature, vibration, excessive movement, noise, and leaks.
8. **Inlets and discharges:** Check that the material is entering and exiting the conveyor freely and at the rate you desire. Hang-ups at either the inlet or discharge can damage the conveyor or related equipment and slow or stop your operation.
9. **Speed:** To prevent system-wide conveyor overfills, check the conveyor speed to ensure it follows the “2 percent” rule: The conveyor should move 2 percent faster than the previous conveyor or feeder.
10. **Lining:** Inspect all lined areas in the conveyor. Because lining is located at wear points, you need to check that the lining is intact and doing its job.
11. **Venting:** Check all venting on your conveyor. If the conveyor requires venting to relieve pressure during material loading, it's a safe bet that moving dust and air will clog the venting at some point.

## Conveying Belt Tension and Alignment

A flat or troughed belt is used to convey material over the spool rollers. The tension and alignment of the belt should be checked weekly, or more often if required, to be sure that it does not slip or run to one side. To maintain the belt, follow this procedure:

### WARNING

Place all controls in neutral or off, stop the motor, and wait for all moving parts to stop. Then disable power source before servicing, adjusting, repairing, or unplugging. Failure to heed may result in personal injury or death.

#### Conveyor Belt Tension:

1. Place all controls in neutral or off, stop motor (s) and disable power source before working on belt.
2. Adjust the take-up adjustment bolt to slacken the tension on the belt until the drive pulley just begins to slip against the belt.

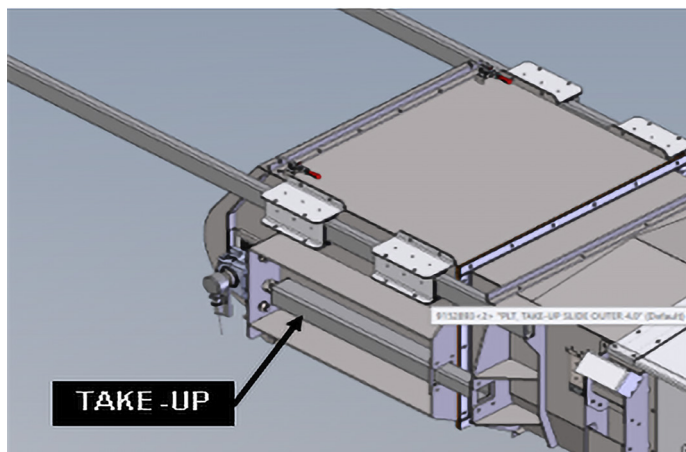

3. Then reapply only the amount of tension necessary to eliminate the slippage.
4. With adequate tension applied to provide the necessary driving friction, the next step is to check all points along the conveyor for excessive sag.

### NOTE

Conveyor belts should be operated at the lowest tension that will accomplish items A and B in order to maximize the life of the conveyor belt and the splice:

- A. Provide for adequate friction at the drive pulley.
- B. And prevent excessive sag between the conveyor pulleys and or spool rollers.

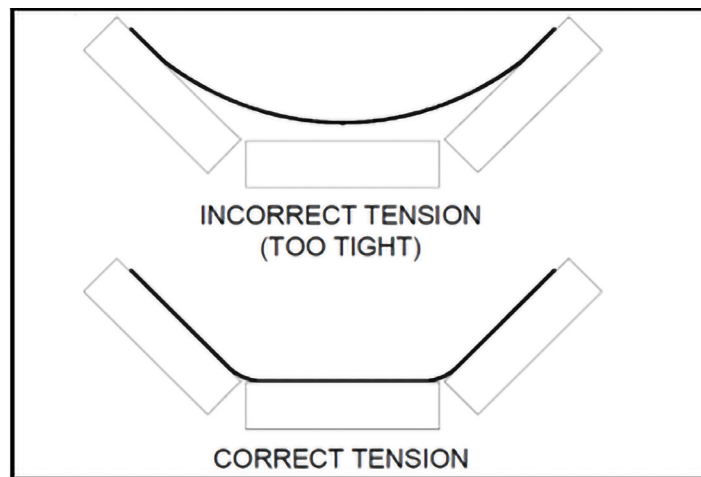

*Check conveyor belt tension*

5. Belt tension for proper sag should always be checked prior to any operation of the conveyor belt. Since there will probably be some belt elongation (stretch) as the belt is operated, the tension should be checked on a regular basis to continually ensure the proper operating conditions.

**Conveyor Belt Tracking and Alignment:**

Tracking is defined as the procedure required to make the conveyor belt run "true" when empty and also when fully loaded. The conveyor belting is properly aligned when the belt runs in the center of the rollers on the ends and at the pivot points.

**WARNING**

Place all controls in neutral or off, stop the motor, and wait for all moving parts to stop. Then disable power source before servicing, adjusting, repairing, or unplugging. Failure to heed may result in personal injury or death.

- A. Level and square all framework and conveyor components.
- B. Use the tail pulley on the intake end to check conveyor belt tracking. The conveyor belt should be centered.

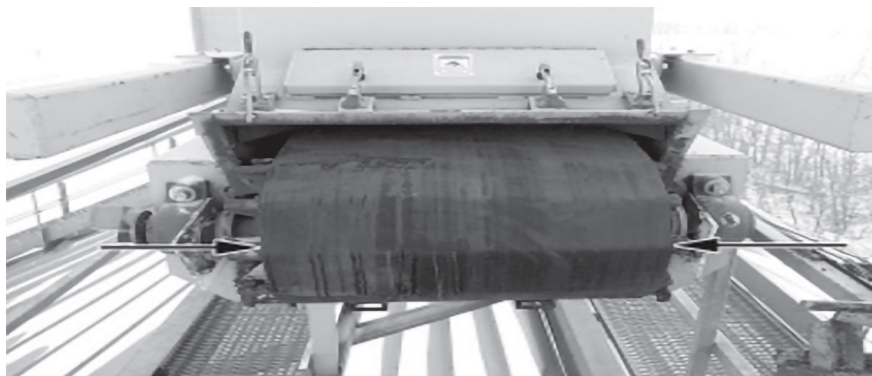

*Check conveyor belt alignment at tail pulley, belt should be centered*

**NOTE**

Conveyor belt drift of 1/2" is considered normal

- C. After installing a new belt, or running the conveyor for the first time. Run the conveyor for increasing time intervals starting with 3 to 5 seconds, watching the conveyor belt track and making adjustments as necessary. If out of alignment, the belt will move to the loose side. Adjust, run and check again. Check frequently during the first few minutes of operation and then several times during the first 10 hours. The belt normally seats itself during the first 10 hours of operation and can be checked weekly after that.

**IMPORTANT**

The first movement of the belt should be slow and intermittent so that any tendency of the belt to run off may be quickly observed and the belt stopped before damage occurs.

- D. When tracking a conveyor which is longer in length or in areas where it might be difficult to communicate to the operator, observers should be stationed at frequent intervals to monitor the action of the belt. They should be provided with a means of communicating to the operator to report their observations and, if necessary tell the operator to stop the conveyor if there is danger of the belt being damaged.

## WARNING

Place all controls in neutral or off, stop the motor, and wait for all moving parts to stop. Then disable power source before servicing, adjusting, repairing, or unplugging. Failure to heed may result in personal injury or death.

- E. A misaligned belt will track towards the loose side. Set the alignment by tightening the loose side.
- F. Begin by making sure that the head and tail pulleys are parallel with each other.
- G. Loosen the take-up adjustment bolt jam nut.
- H. Loosen or tighten the take-up adjustment bolt depending on which side the belt runs to.
- I. Tighten take-up adjustment bolt jam nut to its specified torque.

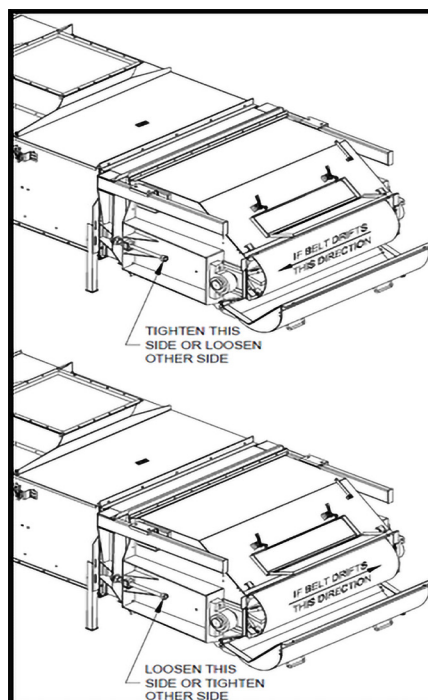

## Conveyor Belt Tracking and Alignment:

Tracking is defined as the procedure required to make the conveyor belt run "true" when empty and also when fully loaded. The conveyor belting is properly aligned when the belt runs in the center of the rollers on the ends and at the pivot points.

### WARNING

Place all controls in neutral or off, stop the motor, and wait for all moving parts to stop. Then disable power source before servicing, adjusting, repairing, or unplugging. Failure to heed may result in personal injury or death.

- A. Level and square all framework and conveyor components.
- B. Use the tail pulley on the intake end to check conveyor belt tracking. The conveyor belt should be centered.

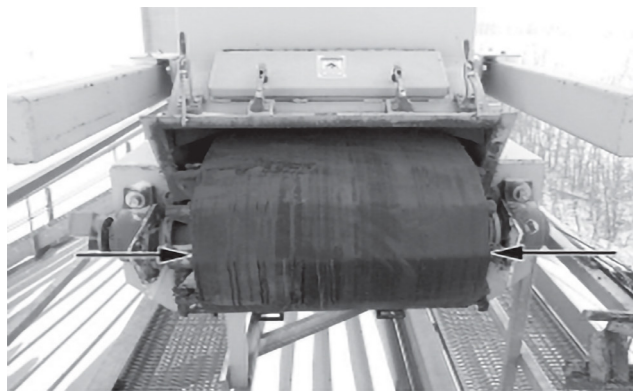

*Check conveyor belt alignment at tail pulley, belt should be centered*

### NOTE

Conveyor belt drift of 1/2" is considered normal

- C. After installing a new belt, or running the conveyor for the first time. Run the conveyor for increasing time intervals starting with 3 to 5 seconds, watching the conveyor belt track and making adjustments as necessary. If out of alignment, the belt will move to the loose side. Adjust, run and check again. Check frequently during the first few minutes of operation and then several times during the first 10 hours. The belt normally seats itself during the first 10 hours of operation and can be checked weekly after that.

### IMPORTANT

The first movement of the belt should be slow and intermittent so that any tendency of the belt to run off may be quickly observed and the belt stopped before damage occurs.

- D. When tracking a conveyor which is longer in length or in areas where it might be difficult to communicate to the operator, observers should be stationed at frequent intervals to monitor the action of the belt. They should be provided with a means of communicating to the operator to report their observations and, if necessary tell the operator to stop the conveyor if there is danger of the belt being damaged.

**Belt Replacement:**

The belt provided on your conveyor should last for several years under normal working conditions, providing it is maintained properly. If a new belt is to be installed, be sure to loop the belt through the conveyor properly. Looping the Conveyor belt improperly will cause belt tracking, belt tensioning, and belt lacing problems. The recommended procedure to replace a belt is:

WARNING

Place all controls in neutral or off, stop the motor, and wait for all moving parts to stop. Then disable power source before servicing, adjusting, repairing, or unplugging. Failure to heed may result in personal injury or death.

- A. Rotate the conveyor belt until the seam is in a clear and open position.
- B. Move the tail roller to the loosest position by following the steps B,C, and D in section (Conveying belt tension and alignment)
- C. Pull all the slack to the seam area.
- D. Remove lacing pin or unbolt fasteners: For Alligator® Ready Set™ Staple Belt Fasteners (see F and Unibar® Fastener type lacing, remove the lacing pin with a vice-grips or similar tool, and open the belt. For Flexco® Bolt Solid Plate type lacing, loosen and remove bolts with a socket wrench, and open belt.

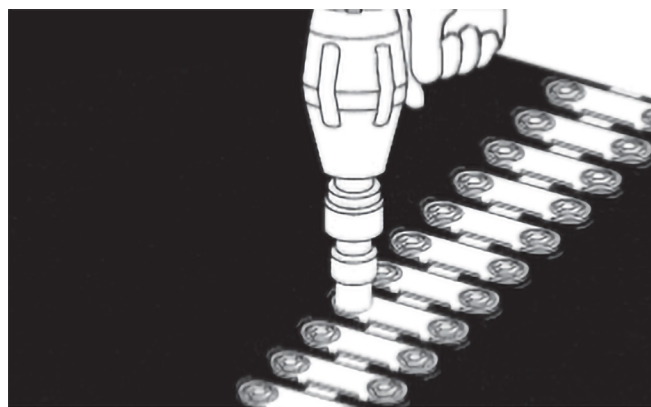
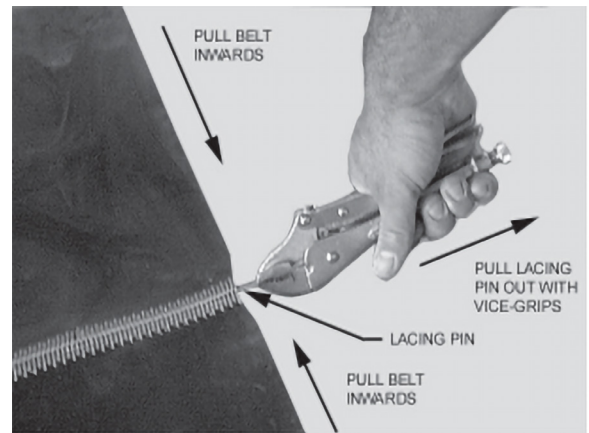
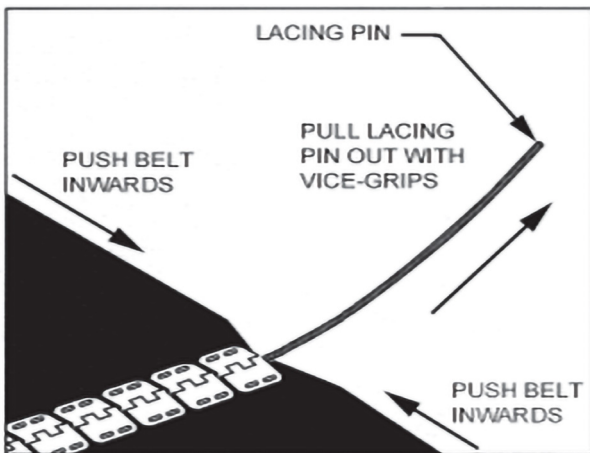



**WARNING**

Never touch a moving belt. Never reach under or through the Conveyor when the belt is running.

**NOTE**

It may be necessary to cut the old lacing from the conveyor belt if the lacing pin cannot be removed.

E. Attach one end of the replacement conveyor belt to the conveyor belt end being removed by means of lacing or clamping.

F. Pull the old conveyor belt out as the new conveyor belt is threaded into place.

G. Disconnect the old conveyor belt.

H. To properly square the belt ends, we recommend the center line method. To properly establish the belt center line, start near the belt end as shown in (Schematic: squaring belt ends).

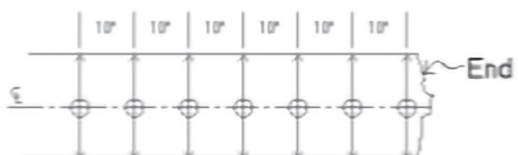

*Schematic: squaring belt ends*

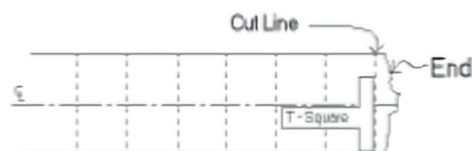

*Schematic: Marking of Cut-Lines*

**NOTE**

If the belt is not cut off truly square, improper belt tracking will occur and serious belt damage can result. Always use a large T-square or equivalent method to make sure that belt ends are cut square at the lacing ends.

I. Measure the belt width at six points approximately 10" apart. Divide each measurement in two and mark these center points as shown. Using these six "center points", draw the resultant "average" center line. (See Schematic: Marking of Cut-Lines)

J. Using a carpenter square or "tee" square, draw a "cut line" across the width of the belt near the belt end (as shown in Schematic: Marking of Cut-Lines). It is also a good idea to mark several right angle reference lines across the belt surface for use as guidelines later on.

K. Using the "cut line" as the guide, cut off the end of the belt with a sharp razor knife. Make sure that the cut is clean and vertical. This operation should then be repeated on the other end of the belt.

L. Connect the ends of the new belt together and secure

**Belt lacing:**

The most common method of joining belt ends is the metal fastener such as the "Clipper" type wire lace or the "Alligator" type steel hinge, as well as others. Fastener manufacturer's catalogs should be consulted for proper size and method of application. Refer to the instructions that came with your type of belt lacing, or consult your Chief representative.

A. Notch the conveyor belt as necessary in order to keep belt from catching conveyor framework.

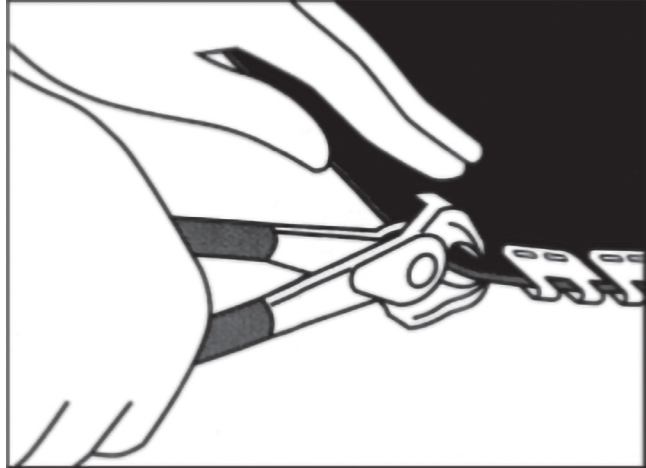

*Notch belt*

B. After applying fasteners to both ends of conveyor belt, mesh loops together and insert the lacing pin.

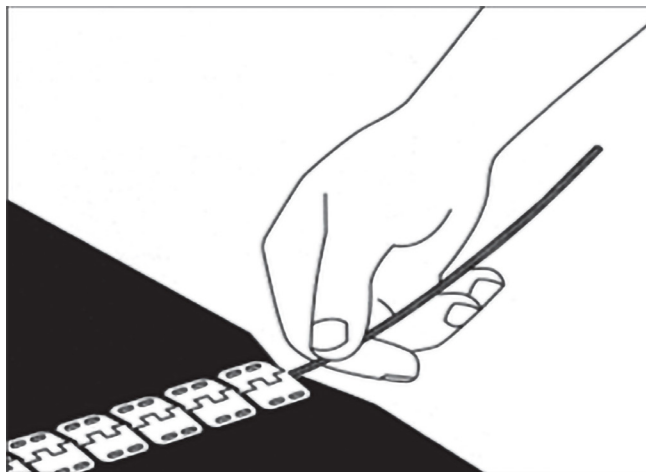

*Lacing pin*

C. Bend lacing pin over flat to prevent snagging on conveyor framework.

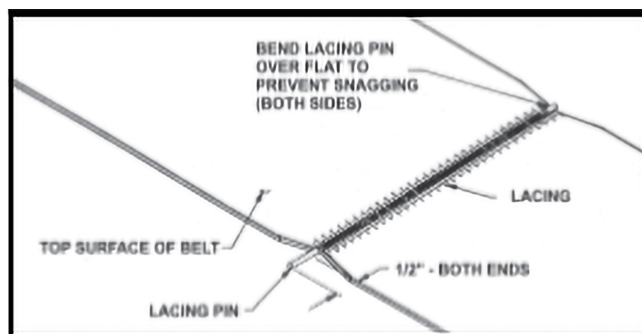

*Bend lacing pin*

## Primary Drive Belt Tension and Alignment

Power to the conveyor belt is transmitted through a V belt primary drive. The drive system must be maintained at the proper belt tension and pulley alignment to obtain the desired performance and life. When maintaining the primary belt drive system, follow this procedure:

### WARNING

Place all controls in neutral or off, stop the motor, and wait for all moving parts to stop. Then disable power source before servicing, adjusting, repairing, or unplugging. Failure to heed may result in personal injury or death.

1. Turn motor off and unplug power cord or turn off power at the master panel before servicing.
2. Belt Tension
  - A. Open or remove guards.
  - B. Set a reference point with a tape measure or rule.

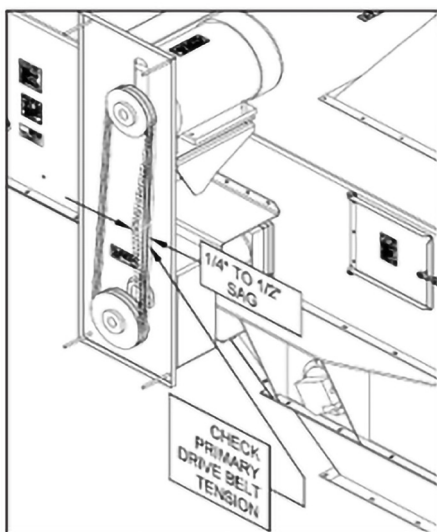

- C. Push on the center span of the belt with a force of approximately 5 to 10 lbs.
- D. The belt will deflect approximately 1/4 to 1/2 inch when properly tensioned.



*Set a reference point with tape measure*



*Push on center span of belt 5-10 lbs.*

**WARNING**

Place all controls in neutral or off, stop the motor, and wait for all moving parts to stop. Then disable power source before servicing, adjusting, repairing, or unplugging. Failure to heed may result in personal injury or death.

- E. If the primary drive belt needs adjustment move the motor base to set primary drive belt tension.
- F. Loosen jam nut.
- G. Turn adjustment nut CCW to raise the motor mount which tightens the belt.
- H. Turn the adjustment nut CW to lower the motor mount which loosens the belt.
- I. Repeat steps B, C and D under (Belt Tension Section), on previous page.
- J. Be sure pulleys are aligned.
- K. Check that the motor mount is parallel with the top plate using a tape measure or rule (4 locations).
- L. Tighten all nuts to their specified torque.
- M. Close and secure guards.

**WARNING**

“Guards and shields are removed for illustrative purposes only; do not operate without guards and shields in place and functioning.”



Loosen jam nut on motor mount



*Adjust to tighten or loosen belt*

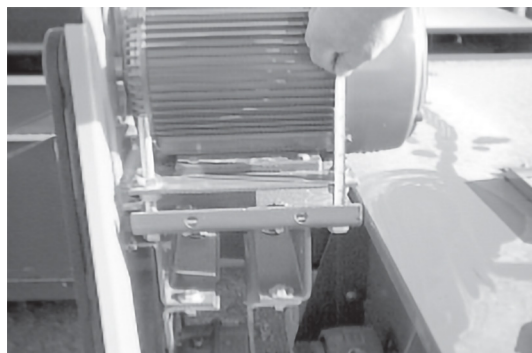

Check that the motor mount is parallel with the top plate (4x)

**WARNING**

Place all controls in neutral or off, stop the motor, and wait for all moving parts to stop. Then disable power source before servicing, adjusting, repairing, or unplugging. Failure to heed may result in personal injury or death.

## 3. Alignment of drive and driven pulley:

- A. Lay a straight-edge across the pulley faces to check the alignment.
- B. Determine which pulley to adjust: Drive pulley or Driven Pulley.
- C. Loosen belt enough to allow drive pulley to be adjusted
- D. Loosen and remove the two bushing bolts from the non-threaded bushing holes and install in the threaded bushing holes.
- E. Tighten the bushing bolts against the pulley face until the pulley breaks free and can be adjusted along the motor shaft.

**NOTE**

When adjusting the drive and driven pulley, move the pulley 1/8" further towards the motor to allow for the adjustment.

- F. Tighten the bushing bolts to its specified torque.
- G. Check belt tension.
- H. Close and secure guards.

**WARNING**

"Guards and shields are removed for illustrative purposes only; do not operate without guards and shields in place and functioning."

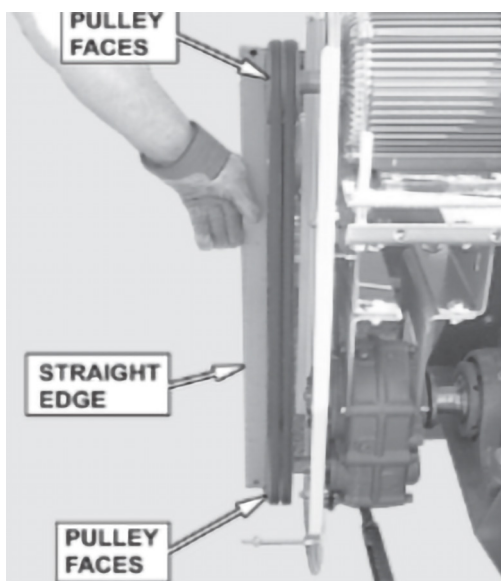

Check alignment of pulleys

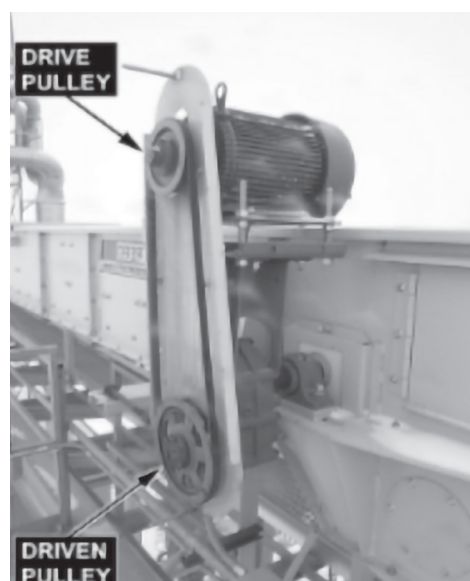

Primary drive anatomy

**WARNING**

Place all controls in neutral or off, stop the motor, and wait for all moving parts to stop. Then disable power source before servicing, adjusting, repairing, or unplugging. Failure to heed may result in personal injury or death.

**4. Drive Belt replacement:**

- A. Move motor to its loosest belt position.
- B. Remove old belt and replace with new one.
- C. Move motor base to set the belt tension.
- D. Check pulley alignment. Adjust if required.
- E. Close and secure guards.

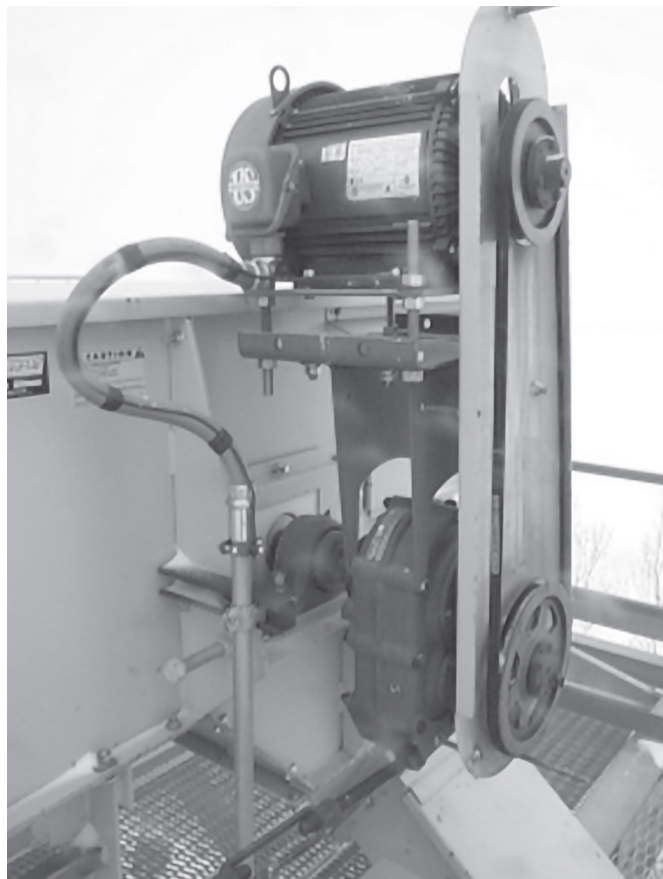

*Belt replacement*

**WARNING**

“Guards and shields are removed for illustrative purposes only; do not operate without guards and shields in place and functioning.”

## Gearbox Oil

Each gearbox is equipped with a drain, level and fill plug. Every 100 hours, or monthly, the oil level should be checked. Bi-annually, the gear oil should be changed. Check more frequently if there are leaks around any of the plugs or shaft seals. When checking gear oil level or changing oil, follow this procedure:

### WARNING

Place all controls in neutral or off, stop the motor, and wait for all moving parts to stop. Then disable power source before servicing, adjusting, repairing, or unplugging. Failure to heed may result in personal injury or death.

#### 1. Checking Oil Level:

- A. When the gearbox is cold, remove the level plug from the side of the gearbox.
- B. When the oil just fills the threads of the level plug, it is at the correct level.
- C. Add oil through the fill plug as required.
- D. Install and tighten level and fill plugs.

#### 2. Changing Oil:

- A. Place a container under the drain plug.
- B. Remove the drain, level and fill plugs.
- C. Allow 10 minutes to drain.
- D. Install and tighten the drain plug.

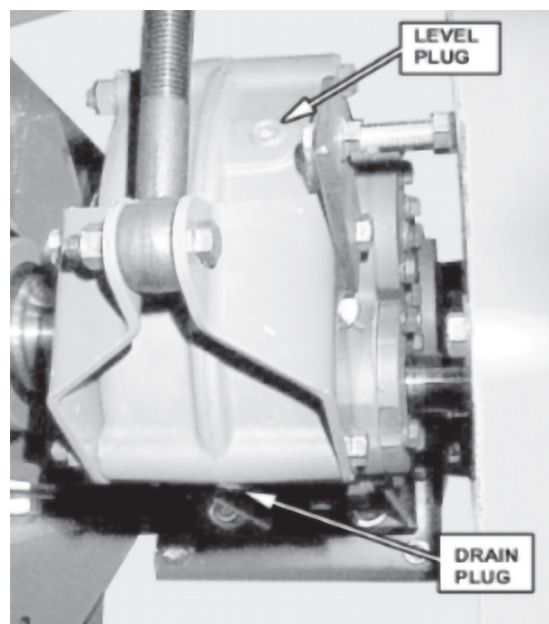

*Gearbox drain and level plugs*

### NOTE

It may be necessary to add Teflon tape or pipe sealant to the drain plug prior to installation to prevent leaking.

- E. Add the recommended gear oil lubricant or equivalent. Use the level plug to determine the proper amount of oil.
- F. Check that the air passage of the breather is open.
- G. Install and tighten the fill and level plugs.
- H. Dispose of the used oil in an environmentally safe manner.

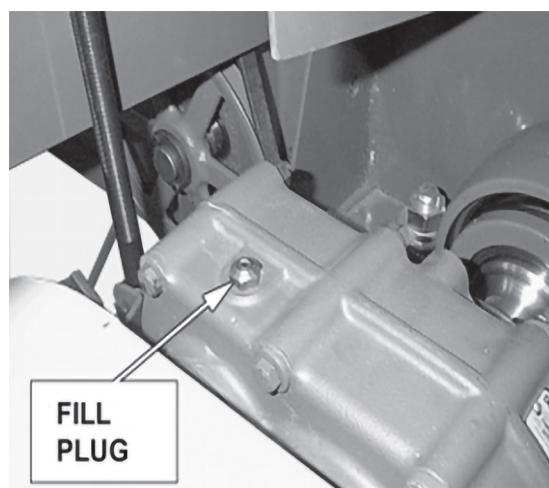

*Gearbox fill plug*

## Breather Cleaning

Each gearbox is equipped with a breather in the fill plug that vents the internal pressure to the atmosphere. As the gearbox temperature increases and decreases during the operating and stopped modes, the pressure in the gearbox will increase or decrease if it is not vented to atmosphere. An increase in internal pressure will cause the shaft seals to leak until the gearbox runs low on or out of oil. To check or clean the breather, follow this procedure:

### WARNING

Place all controls in neutral or off, stop the motor, and wait for all moving parts to stop. Then disable power source before servicing, adjusting, repairing, or unplugging. Failure to heed may result in personal injury or death.

1. Remove the fill plug/breather from the gearbox.
2. Check that the vent passage through the plug is open.
3. If plugged, soak in a solvent.
4. Use a high-pressure air hose to blow the passage open. Use a probe to clear the passage if the hole is caked with dirt.
5. Install and tighten the breather plug.

### NOTE

Always clean the breather if any leaks are noticed around shafts.

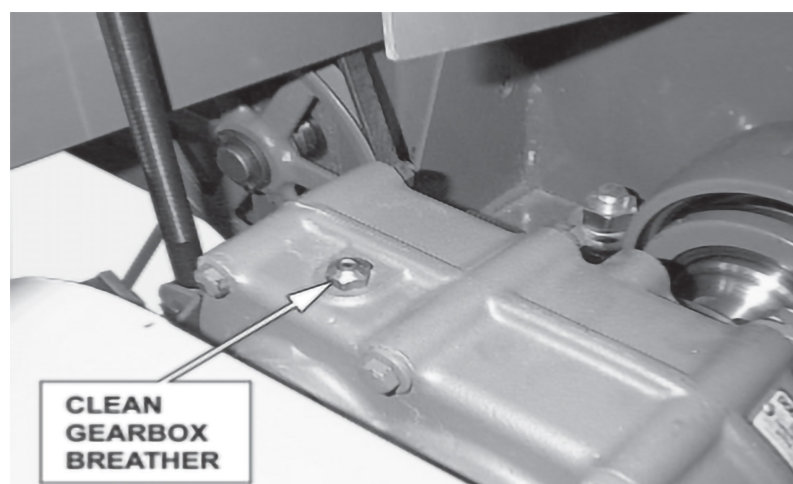

*Clean gearbox fill plug / breather*



## Troubleshooting

The Chief Spool Enclosed Belt conveyor uses an endless flat belt moving over troughed spool rollers inside a enclosed frame to convey material from one location to another. It is a simple and reliable system that requires minimal maintenance. In the following section, we have listed many of the problems, causes and solutions to the problems that you may encounter.

If you encounter a problem that is difficult to solve, even after having read through this trouble shooting section, please call your local Chief dealer or distributor. Before you call, please have this Operator's Manual and the serial number from your machine ready.

<b>PROBLEM</b>	<b>CAUSE</b>	<b>SOLUTION</b>
Conveyor will not run.	Not turned on.	Start power source or turn on power.
	Conveying belt loose.	Tighten and align belt
	Drive belt loose.	Tighten drive belt.
Belt edge fraying.	Belt not aligned.	Align belt.
Low conveying capacity	Slow operating speed.	Increase operating speed.
	Conveying belt slipping	Tighten belt.
	Drive belt loose.	Tighten drive belt.

## Troubleshooting For Conveyor Belting

Listing below are a number of common problems that can be related to corrugated sidewall belting. Proper maintenance can reduce the incidence of these difficulties.

PROBLEM	CAUSE / CURE IN ORDER OF PROBABLE OCCURRENCE						
	(See next two pages for explanation of codes)						
Belt runs off at tail pulley.	7	14	13	18	20	-	
Entire belt runs off at all points of the line.	24	16	14	20	4	15	
One belt section runs off at all points of the line.	2	10	1	-	-	-	
Belt runs off at head pulley	14	21	20	15	-	-	
Belt runs to one side throughout entire length at specific rollers.	14	15	20	-	-	-	
Belt slip.	18	7	20	13	21	-	
Belt slip on starting.	18	7	21	9	-	-	
Excessive belt stretch.	12	9	20	6	8	-	
Belt breaks at or behind fasteners; fasteners tear loose.	2	22	12	21	19	9	
Vulcanized splice separation.	12	22	9	19	2	-	
Excessive wear, including rips, gouges, ruptures and tears.	11	23	16	20	8	5	
Excessive bottom cover wear.	20	13	5	18	19	21	
Excessive edge wear, broken edges.	24	4	16	8	1	20	
Cover swells in spots or streaks.	8	-	-	-	-	-	
Longitudinal grooving or cracking	13	20	21	-	-	-	
Fabric decay, carcass cracks, Ruptures, gouges (soft spots in belt).	11	19	5	9	8	-	
Ply separation.	12	22	10	8	3	-	

## Cause And Cures For Common Belt Problems

- 1.) **Belt bowed** - Avoid telescoping belt rolls or storing them in damp locations. A new belt should straighten out when “broken in” or it must be replaced.
- 2.) **Belt improperly spliced or wrong fasteners** - Use correct fasteners. Re-tighten after running for a short while. If improperly spliced, remove belt splice and make new splice.
- 3.) **Belt speed too fast** - Reduce belt speed.
- 4.) **Belt strained on one side** - Allow time for new belt to “break in”. If belt does not break in properly or is not new, removed strained section and splice in a new piece.
- 5.) **Breaker strip in vulcanized splice missing or inadequate** - When service is lost, install belt with proper breaker strip.
- 6.) **Take up tension too high** - Recalculate tension required and adjust take-up accordingly. Reduce take-up tension to point of slip, then tighten slightly.
- 7.) **Counterweight too light** - Recalculate weight required and adjust counter weight or screw take-up accordingly.
- 8.) **Damage by abrasives, acid, chemicals, heat, mildew, oil** - Use belt designed for specific condition. For abrasive materials working into cuts and between plies, make spot repairs with cold patch or with permanent repair patch. Seal metal fasteners or replace with vulcanized step splice. Enclose belt line for protection against rain, snow, or sun. Don’t over lubricate rollers.
- 9.) **Drive underbelted** - Recalculate maximum belt tensions and select correct belt. If line is over-extended, consider using two-flight system with transfer point. If carcass is not rigid enough for load, install belt with proper flexibility when service is lost.
- 10.) **Edge worn or broken** - Repair belt edges. Remove badly worn or out-of-square section and splice in a new piece.
- 11.) **Excessive impact of material on belt or fasteners** - Use correctly designed chutes and baffles. Make vulcanized splices. Install loading rollers. Where material is trapped under skirts, adjust skirtboards to minimum clearance or install cushioning rollers to hold belt against skirts.
- 12.) **Excessive tension** - Recalculate and adjust tension. Use vulcanized splice within recommended limits.
- 13.) **Frozen rollers** - Free rollers, lubricate. Improve maintenance (Don’t over lubricate).
- 14.) **Spool rollers or pulleys out-of-square with center line of conveyor** - Realign. Install limit switches for greater safety.
- 15.) **Rollers improperly placed** - Relocate rollers or insert additional rollers spaced to support belt.
- 16.) **Improper loading** - Feed should be in direction of belt travel and at belt speed, centered on the belt.
- 17.) **Improper storage or handling** - Store belt in dry area. Do not lay belt on its side.
- 18.) **Insufficient traction between belt and pulley** - Lag drive pulley. In wet conditions, use grooved lagging. Install correct cleaning devices for safety.
- 19.) **Material between belt and pulley** - Use skirtboards properly. Remove accumulation. Install cleaning devices. Improve housekeeping.
- 20.) **Material build-up** - Remove accumulation. Install cleaning devices. Improve housekeeping.
- 21.) **Pulley lagging worn** - Replace worn pulley lagging. Use grooved lagging for wet conditions. Tighten loose and protruding bolts.
- 22.) **Pulleys too small** - Use larger diameter pulleys,
- 23.) **Relative loading velocity too high or too low** - Adjust chutes or correct belt speed. Consider use of loading rollers.
- 24.) **Side loading** - Load in direction of belt travel, in center of conveyor.

# Specifications

## General Specifications

SPECIFICATIONS	
CONVEYOR BELT	Heavy-duty industrial belt with mechanical fastener.
BELT SPEEDS	50-700 FPM
BELT WIDTHS	18", 24", 30", 36", 42", 48" & 54" 2 ply Nylon Rubber Covered
HEAD PULLEY	12" or 14" Diameter, vulcanized rubber lagging
TAIL PULLEY	12" Diameter
BEARINGS	Pillow block bearings at all terminal shafts.
SPOOL ROLLERS	Equal length offset rollers standard.
FRAME CONSTRUCTION	Enclosed Frame
COVERS	Standard

## Capacities

CAPACITIES (Cubic Feet Per Hour)										
Conveyor Belt Width (In Inches)	Belt Speed in Feet Per Minute									
	100	200	300	400	450	500	550	600	650	700
18	1324	2647	3971	5294	5956	6618	7279	7941	8603	9265
24	2298	4596	6894	9193	10342	11491	12640	13789	14938	16087
30	3809	7619	11428	15237	17142	19046	20951	22856	24860	26665
36	5236	10472	14708	20944	23561	26179	28797	31415	34033	36651
42	677	13554	20331	27109	30497	338866	37274	40663	44051	47440
48	8433	16866	25299	33733	37949	42166	46382	50599	54815	59032
54	10204	20408	30611	40815	45917	51019	56121	61223	66324	71426

<b>CAPACITIES (Bushel Per Hour)</b>										
Conveyor Belt Width (In Inches)	<b>Belt Speed in Feet Per Minute</b>									
	100	200	300	400	450	500	550	600	650	700
<b>18</b>	1059	2118	3176	4235	4765	5294	5823	6353	6882	7412
<b>24</b>	1839	3677	5516	7354	8273	9193	10112	11031	11950	12870
<b>30</b>	3047	6095	9142	12190	13713	15237	16761	18284	19808	21332
<b>36</b>	4189	8377	12566	16755	18849	20944	23038	25132	27227	29321
<b>42</b>	5422	10843	16265	21687	24398	27109	29819	32530	35241	37952
<b>48</b>	6747	13493	20240	26986	30359	33733	37106	40479	43852	47226
<b>54</b>	8163	16326	24489	32652	36734	40815	44897	48978	53060	57141

### Maximum Belt Speeds

<b>Recommended Maximum Belt Speeds</b>		
<b>Material Being Conveyed</b>	<b>Belt Speed (fpm)</b>	<b>Belt Width (inches)</b>
Grain or other free-flowing, non-abrasive material	500	18
	600	24-30
	700	36-42
	700	48-54
Coal, damp clay, soft ores, overburden and earth, fine crushed stone	400	18
	600	24-36
	700	42-54
Heavy, hard, sharp-edged ore, coarse-crushed stone	350	18
	500	24-36
	600	42-54
Foundry sand, prepared or damp; shakeout sand with small cores	350	All widths

## Flowability of Materials

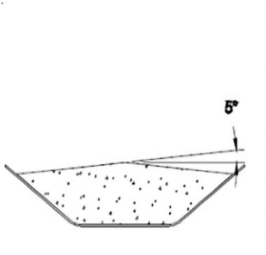
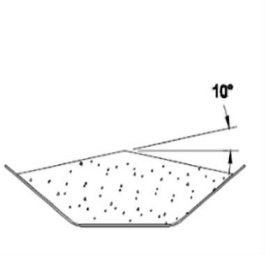
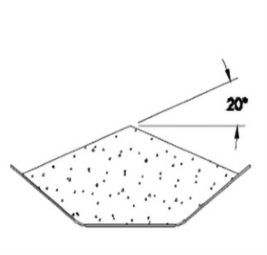
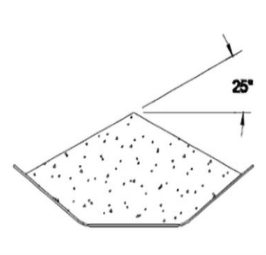
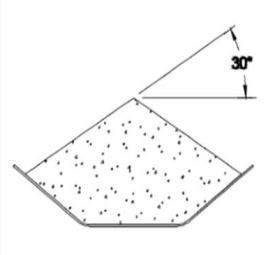
Flowability - Angle of Surcharge - Angle of Repose				
Very free flowing 1*	Free flowing 2*	Average flowing 3*		Sluggish 4
5° Angle of surcharge	10° Angle of surcharge	20° Angle of surcharge	25° Angle of surcharge	30° Angle of surcharge
				
0° - 19° Angle of repose	20° - 29° Angle of repose	30° - 34° Angle of repose	35° - 39° Angle of repose	40° - up Angle of repose
Material characteristics				
Uniform size, very small rounded particle, either very wet or very dry, such as dry silica sand, cement, wet concrete, etc.	Rounded, dry polished particles, of medium weight, such as whole grain and beans.	Irregular, granular or lumpy materials of medium weight, such as anthracite coal, cottonseed meal, clay, etc.	Typical common materials such as bituminous coal, stone, most ores, etc.	Irregular, stringy, fibrous, interlocking material, such as wood chips, bagasse, tempered foundry sand, etc.

\* Code designations conform to bulk material characteristics chart.